

# OWNER'S MANUAL

## JD 6.5HP 4-stroke Engine Recoil Start



# OWNER'S MANUAL

Assembly & Operating Instructions

## JD 6.5HP STATIONARY 4 STROKE ENGINE RECOIL START

MODEL NO. JD-BE-6.5HP



## To the Owner

Thank you for purchasing our JD 6.5hp Engine. It was carefully engineered to provide excellent performance when properly operated and maintained.

Please read this entire manual prior to operating the equipment. It instructs you how to safely and easily set up, operate and maintain your machine. Please be sure that you and any other persons who will operate the machine carefully follow the recommended safety practices at all times. Failure to do so could result in personal injury or property damage.

All information in this manual is relative to the most recent product information available at the time of printing. Review this manual frequently to familiarise yourself with the machine, its features and operation. Please be aware that this Owner's Manual may cover a range of product specifications for various models. Characteristics and features discussed and/or illustrated in this manual may not be applicable to all models. We reserve the right to change product specifications, designs and equipment without notice and without incurring obligation.

All the power testing information used to establish the power rating of the engine equipped on this machine can be found in the engine manufacturer's manual or website. If you have any problems or questions concerning the machine, please contact our Customer Support Department.

Throughout this manual, all references to right and left side of the machine are observed from the operating position. The engine manufacturer is responsible for all engine-related issues with regards to performance, power-rating, specifications, warranty and service. Please refer to the engine manufacturer's Owner's Manual packed separately with your machine for more information.

## Customer Support

*Please DO NOT return the machine without first contacting the Customer Support Department at [bbt@bbta.com.au](mailto:bbt@bbta.com.au).*

If you have difficulty assembling this product or have any questions regarding the controls, operation, or maintenance of this machine, please contact our Customer Support Department.

**SAVE THESE INSTRUCTIONS**

# TABLE OF CONTENTS

	Page(s)		Page(s)
To the Owner .....	2	<b>TROUBLESHOOTING</b> .....	<b>16</b>
Customer Support.....	2	<b>STORAGE</b> .....	<b>17-18</b>
<b>TABLE OF CONTENTS</b> .....	<b>3</b>	Cleaning .....	17
<b>IMPORTANT SAFETY INFORMATION</b> .....	<b>4-5</b>	Fuel .....	17
Additional Information and Potential Changes.....	4	Adding a Fuel Stabilizer to Extend Fuel Storage Life.....	17
Key to Symbols.....	5	Draining the Fuel Tank and Carburettor .....	18
<b>PARTS LOCATION</b> .....	<b>6</b>	Engine Oil.....	18
<b>BEFORE OPERATION</b> .....	<b>7</b>	Storage Precautions.....	18
Pre-operation Check .....	7	Removal from Storage.....	18
Check the General Condition of the Engine .....	7	Transporting .....	18
Check the Engine .....	7	<b>OPTIONAL</b> .....	<b>19</b>
Check the Equipment Powered by this Engine .....	7	Remote Control Linkage (Optional) .....	19
<b>PRE-OPERATION CHECK</b> .....	<b>8-9</b>	Carburettor Modification for High Altitude Operation...	19
Engine Oil Level Check .....	8	Replacement Parts .....	19
Engine Oil Change .....	8	<b>TECHNICAL AND CONSUMER INFORMATION</b> .....	<b>20</b>
Engine Oil Recommendations.....	8	Wiring Diagrams .....	20
Refuelling .....	9	<b>SPECIFICATIONS</b> .....	<b>21</b>
Fuel Recommendations .....	9	<b>WARRANTY &amp; SERVICE</b> .....	<b>22</b>
<b>OPERATION</b> .....	<b>10-11</b>	Warranties.....	22
Safe Operating Precautions .....	10	Spare Parts.....	22
Starting the Engine.....	10	<b>EXPLODED DIAGRAM &amp; PARTS LIST</b> .....	<b>23-27</b>
Setting Speed .....	11	<b>YOU MAY ALSO LIKE</b> .....	<b>28</b>
Stopping The Engine .....	11		
<b>SERVICE &amp; MAINTENANCE</b> .....	<b>12-15</b>		
The Importance of Maintenance .....	12		
Maintenance Safety.....	12		
Safety Precautions .....	12		
Maintenance Schedule .....	13		
Air Filter Inspection and Service.....	14		
Dual-filter-Element Type .....	14		
Sediment Cup Cleaning .....	14		
Spark Plug Service.....	15		
Idle Speed Adjustment .....	15		



## IMPORTANT SAFETY INFORMATION



**WARNING:** Read and thoroughly understand all instructions in this manual and on the safety decals before assembling or operating this Engine. Failure to do so may cause serious injury or death. Do not allow anyone to operate this machine who has not read this manual. As with all power equipment, a machine can be dangerous if assembled or used improperly. Do not operate this machine if you have any questions concerning its safe operation. To get answers to any questions, call our Customer Support Department.



This SAFETY ALERT SYMBOL identifies important safety messages in this manual. Failure to follow this important safety information may result in serious injury or death.



**DANGER!** This machine was built to be operated according to the safe operation practices in this manual. As with any type of power equipment, carelessness or error on the part of the operator can result in serious injury. Failure to observe the following safety instructions could result in serious injury or death.

The following signals, words and meanings are intended to explain the levels of risk associated with this product.



**DANGER**

**DANGER** indicates a hazardous situation which, if not avoided, will result in serious injury or death.



**WARNING**

**WARNING** indicates a hazardous situation which, if not avoided, could result in serious injury or death.



**CAUTION**

**CAUTION** indicates a hazardous situation which, if not avoided, could result in minor or moderate injury.

**NOTICE**

**NOTICE** is important information about the proper use of your machine. Failure to follow this instruction could result in damage to your machine or property.

### Additional Information and Potential Changes

We reserve the right to discontinue, change, and improve our products at any time without notice or obligation to the purchaser. The descriptions and sections contained in this manual were in effect at the time of printing. Equipment described within this manual may be optional. Some illustrations may not be applicable to your machine.



**WARNING!** Your Responsibility—Restrict the use of this power machine to persons who have read, understood and will follow the warnings and instructions in this manual and on the machine.

**SAVE THESE INSTRUCTIONS!**

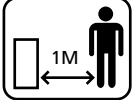

# IMPORTANT SAFETY INFORMATION

## Key to Symbols

Symbol	Description
	<b>READ THE OWNER'S MANUAL(S)</b> Read, understand and follow all instructions in the manual(s) before attempting to assemble and operate.
	<b>BYSTANDERS</b> Keep bystanders, helpers, pets, and children at least 1 metre from the machine while it is in operation. Stop machine if anyone enters the area.
	<b>PETROL IS FLAMMABLE</b> Petrol is extremely flammable. Allow the engine to cool for at least ten minutes before refuelling.
	<b>CAUTION!</b> Tool surfaces can be hot.

Most accidents with engines can be prevented if you follow all instructions in this manual and on the engine. Some of the most common hazards are discussed below, along with the best way to protect yourself and others

### **WARNING**

The warnings, cautions and instructions discussed in this Owner's Manual cannot cover all possible conditions and situations that may occur. It must be understood by the operator that **COMMON SENSE AND CAUTION ARE FACTORS WHICH CANNOT BE BUILT INTO THIS PRODUCT, BUT MUST BE SUPPLIED BY THE OPERATOR.**

- Read and understand this owner's manual before operating the engine. Failure to do so could result in personal injury or equipment damage.
- Know how to stop the engine quickly, and understand the operation of all the controls. Never permit anyone to operate the engine without proper instructions.
- **DO NOT** allow children to operate the engine. Keep children and pets away from the area of operation.
- **DO NOT** operate engine in explosive atmospheres, such as in the presence of flammable liquids, gases, or dust. Engines create sparks, which may ignite the dust or fumes.
- Dress properly. **DO NOT** wear loose clothing or jewellery. Contain long hair. Keep your hair, clothing, and gloves away from moving parts. Loose clothes, jewellery, and long hair can be caught in moving parts.
- Petrol is extremely flammable and fuel vapour can explode. Refuel outdoors in a well ventilated area, with the engine stopped. **NEVER** smoke near petrol, and keep other flames and sparks away. Always store fuel in an approved container. If any fuel is spilled, make sure the area is dry before starting the engine.
- The muffler becomes very hot during operation and remains hot for a while after stopping the engine. Be careful not to touch the muffler while it is hot. Let the engine cool before storing it indoors.
- To prevent fire hazards and to provide adequate ventilation for stationary equipment applications, keep the engine at least 1 metre away from building walls and other equipment during operation.
- **DO NOT** place flammable objects close to the engine.
- Exhaust fumes contain poisonous carbon monoxide. Avoid inhalation of exhaust fumes. **NEVER** run the engine in a closed garage or confined area.
- Review the instructions provided with the equipment powered by this engine for any additional safety precautions that should be observed in conjunction with engine start-up, shutdown, operation, or protective apparel that may be needed to operate the equipment.
- **DO NOT** overload the engine. Use the correct engine for your application. The correct engine will do the job better and safer at the rate for which it is designed.

# PARTS LOCATION

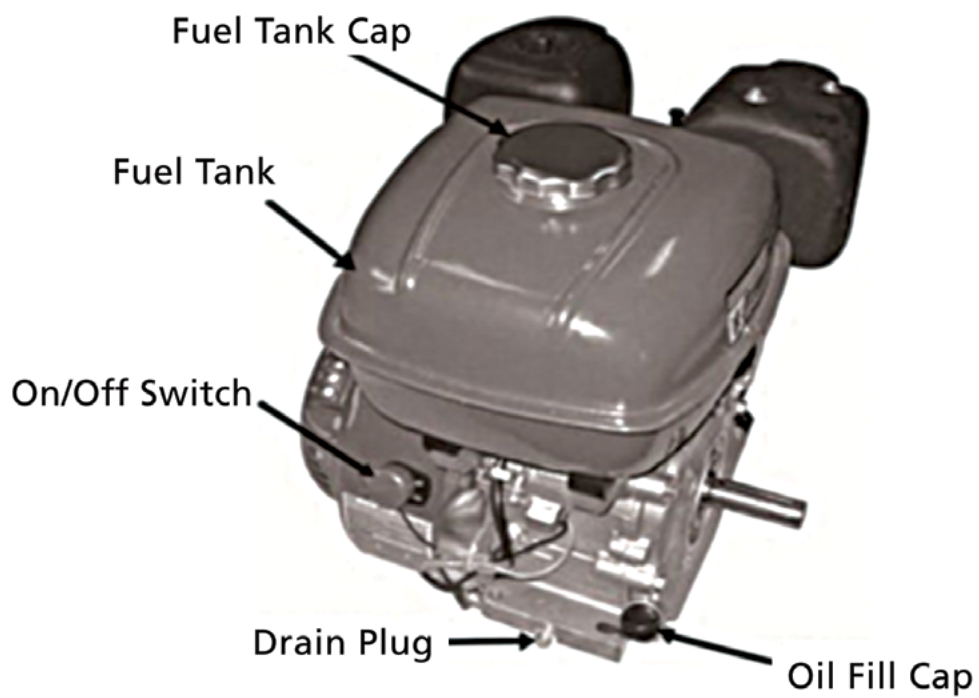
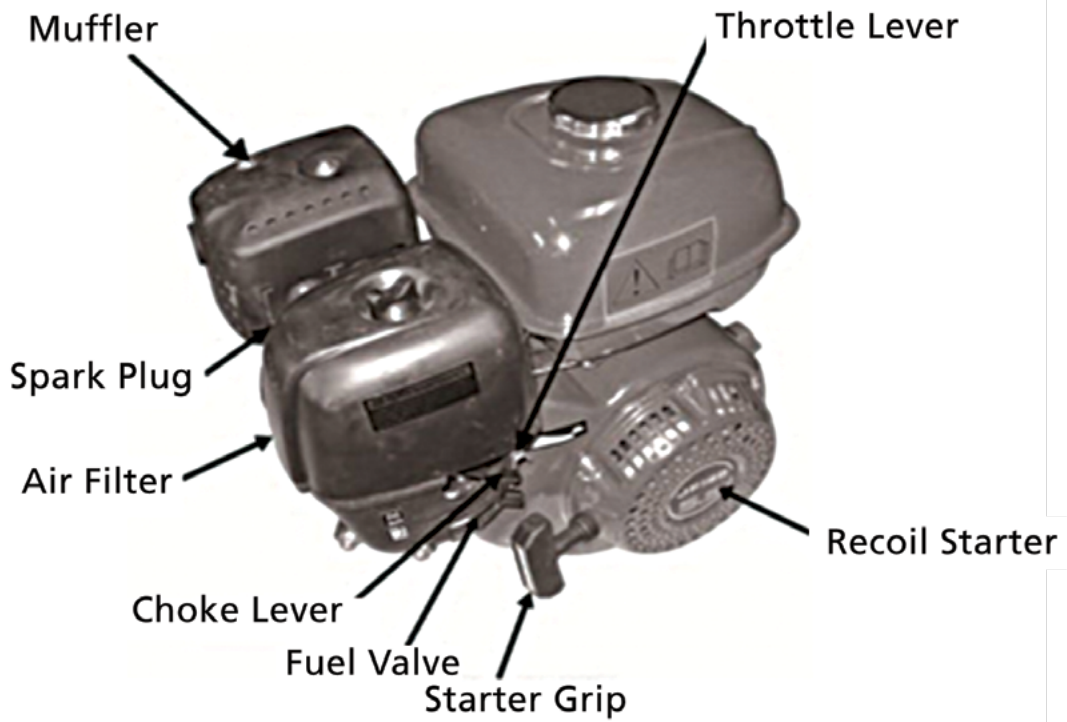

# BEFORE OPERATION

## Pre-operation Check

For your safety, and to maximize the service life of your equipment, it is very important to take a few moments before you operate the engine to check its condition. Be sure to take care of any problem you find, or have your servicing dealer correct it, before you operate the engine.

### **WARNING**

Improper maintenance on this engine, or failing to correct a problem before operation, could cause a malfunction in which you could be seriously injured.

Always perform a pre-operation inspection before each operation, and correct any problem.

Before beginning your pre-operation checks, be sure the engine is level and the engine switch is in the **OFF** position.

## Check the General Condition of the Engine

- Look around and underneath the engine for any signs of damage or signs of oil or fuel leaks.
- Remove any excessive dirt or debris.
- Check that all shields and covers are in place, especially around the muffler and recoil starter, and all nuts, bolts and screws are tightened.

## Check the Engine

- Check the engine oil level. Running the engine with a low oil level can cause engine damage. The Oil sensor will automatically stop the engine before the oil level falls below a safe limit. However, to avoid the inconvenience of an unexpected shutdown, always check the engine oil level before engine start-up.
- Check the air filter. A dirty air filter will restrict air flow to the carburettor, reducing engine performance.
- Check the fuel level. Starting with a full tank will help to eliminate or reduce operating interruptions for refuelling.

## Check the Equipment Powered by this Engine

Review the instructions provided with the equipment powered by this engine for any precautions and procedures that should be followed before engine start-up.

### **WARNING**

Carbon monoxide gas is toxic. Breathing it can cause unconsciousness and even death. Avoid any areas or actions that expose you to carbon monoxide.



# PRE-OPERATION CHECK

## Engine Oil Level Check

Stop the engine, disconnect the spark plug and place engine in a level position before checking the engine oil level.

1. Remove the filler cap/dipstick and wipe it clean.
2. Insert and remove the dipstick without screwing it into the filler neck. Check the oil level shown on the dipstick.
3. If the oil level is low, fill to the edge of the oil filler hole with the recommended oil.
4. Screw in the filler cap/dipstick securely.

### NOTICE

**Running the engine with a low oil level can cause engine damage.** The oil sensor will automatically stop the engine before the oil level falls below safe limit. However, to avoid the inconvenience of an unexpected shutdown, always check the engine oil level before start-up.

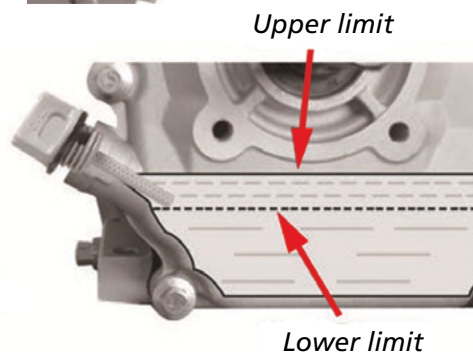
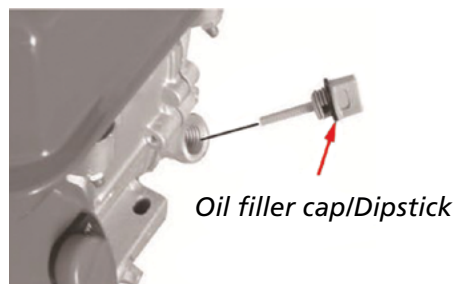

## Engine Oil Change

Drain the used oil while the engine is warm. Warm oil drains quickly and completely.

1. Place a suitable container below the engine to catch the used oil, then remove the filler cap/dipstick, drain plug, and washer.
2. Allow the used oil to drain completely, then reinstall the drain plug, washer, and tighten drain plug securely.

Please dispose of used motor oil in a manner that is compatible with the environment. We suggest you take used oil in a sealed container to your local recycling centre or service station for reclamation. **DO NOT** throw it in the trash; pour it on the ground, or down a drain.

3. With the engine in a level position, fill to the outer edge of the oil filler hole with the recommended oil.
4. Screw in the filler cap/dipstick securely.

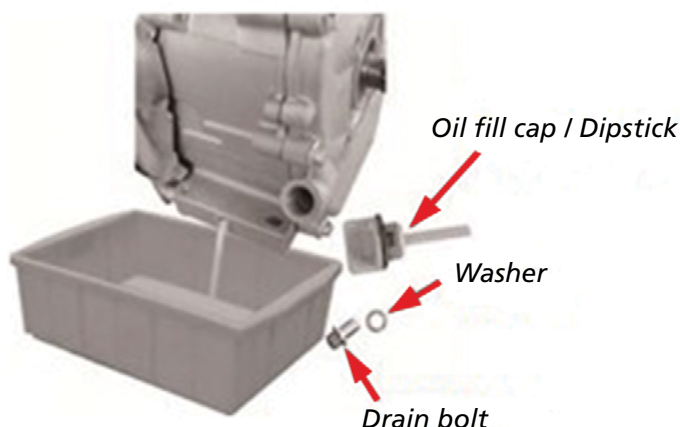

## Engine Oil Recommendations

Oil is a major factor affecting performance and service life. Use 4-stroke automotive engine oil.

SAE 30 is recommended for general use. Other viscosities shown in the chart may be used when the average temperature in your area is within the recommended range.

The SAE oil viscosity and service classification are in the API label on the oil container. The expert recommends that you use API SERVICE category SJ or SL oil.

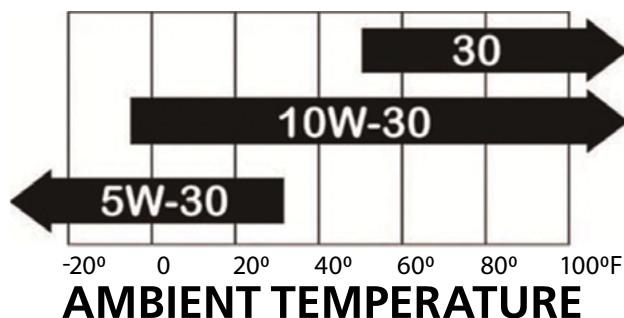

# PRE-OPERATION CHECK

## Refuelling

Stop the engine, disconnect the spark plug and place engine in a level position before checking the fuel level. Refill the tank if the fuel level is low.

### ⚠ WARNING

Petrol is highly flammable and explosive. You can be burned or seriously injured when handling fuel.

- Stop the engine and keep heat, sparks, and flame away.
- Handle fuel only outdoors
- Wipe up spills immediately.

MAXIMUM FUEL LEVEL

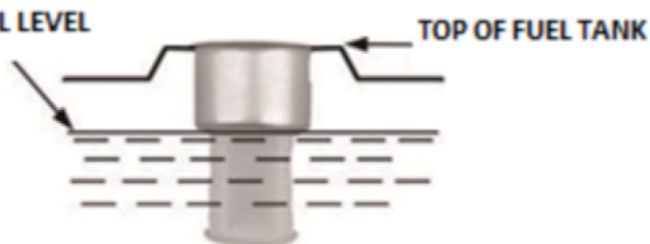

- Refuel in a well-ventilated area before starting the engine. If the engine has been running, allow it to cool. Refuel carefully to avoid spilling fuel. **DO NOT** fill the fuel tank completely.
- Fill tank to approximately 1 inch (25 mm) below the top of the fuel tank to allow for fuel expansion. It may be necessary to lower the fuel level depending on operating conditions. After refuelling, tighten the fuel tank cap securely.
- **NEVER** refuel the engine inside a building where petrol fumes may reach flames or sparks.
- Keep petrol away from pilot lights, barbeques, electric appliances, power tools, etc.
- Spilled fuel is not only a fire hazard, it causes environmental damage. Wipe up spills immediately.

### NOTICE

Fuel can damage paint and plastic. Be careful not to spill fuel when filling your fuel tank. Damage caused by spilled fuel is not covered under warranty.

## Fuel Recommendations

- Use unleaded petrol with an octane rating of 95 or higher.
- These engines are certified to operate on unleaded petrol. Unleaded petrol produces fewer engine and spark plug deposits and extends the exhaust system life.
- **NEVER** use stale or contaminated fuel or an oil/fuel mixture. Avoid getting dirt or water in the fuel tank.
- Occasionally you may hear a light "spark knock" or "pinging" (metallic rapping noise) while operating under heavy loads. This is no cause for concern. If spark knock or pinging occurs at a steady engine speed, under normal load, change brands of petrol.

### NOTICE

Running the engine with persistent spark knock or pinging can cause engine damage. Running the engine with persistent spark knock or pinging is considered misuse, and the Distributor's Limited Warranty does not cover parts damaged by misuse.

# OPERATION

## Safe Operating Precautions

Before operating the engine for the first time, please review the **IMPORTANT SAFETY INFORMATION**.

Review the instructions provided with the equipment powered by this engine for any safety precautions that should be observed in conjunction with engine start-up, shutdown or operation.

### **⚠ WARNING**

- Engine exhaust contains carbon monoxide, an odourless and deadly gas.
- Avoid any areas or actions that expose you to carbon monoxide.

## Starting the Engine

1. Move the fuel valve lever to the **ON** position. The fuel valve opens and closes the passage between the fuel tank and the carburettor. The fuel valve lever must be in the **ON** position for the engine to run.
2. To start a cold engine, move the choke lever to the **CLOSED** position. To restart a warm engine, leave the choke lever in the **OPEN** position. The choke lever opens and closes the choke valve in the carburettor.

The **CLOSED** position enriches the fuel mixture for starting a cold engine. The **OPEN** position provides the correct fuel mixture for operation after starting, and for restarting a warm engine.

3. Move the throttle lever away from the **SLOW** position, about 1/3 of the way toward the **FAST** position. The throttle lever controls engine speed. Moving the throttle lever in one direction or the other, makes the engine run faster or slower.
4. Turn the engine switch to the **ON** position. The engine switch enables and disables the ignition system. The engine switch must be in the **ON** position for the engine to run. Turning the engine switch to the **OFF** position stops the engine. (Fig A)
5. To operate the RECOIL STARTER:  
Pull the starter grip lightly until you feel resistance, then pull briskly. Return the starter grip gently. Pulling the starter grip operates the recoil starter to crank the engine. (Fig B)
6. If the choke lever has been moved to the **CLOSED** position to start the engine, gradually move it to the **OPEN** position as the engine warms up. (Fig C)

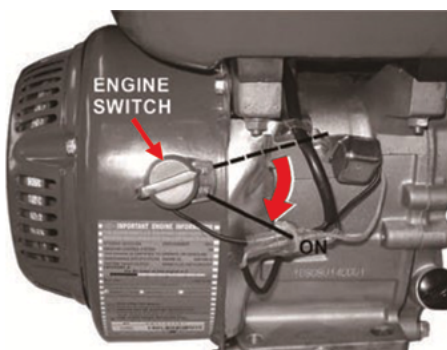

Fig A



Fig B

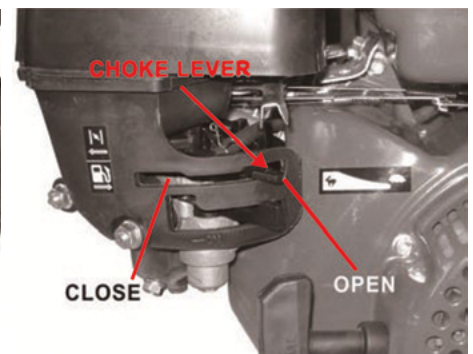

Fig C

# OPERATIONS

## Setting Speed

Position the throttle lever for the desired engine speed.

Moving the throttle lever in the directions shown makes the engine run faster or slower.



Some engine applications use a remote-mounted throttle control rather than the engine-mounted throttle lever shown here.

For engine speed recommendations, refer to the instructions provided with the equipment powered by this engine.

## ! WARNING

Carbon monoxide gas is toxic. Breathing it can cause unconsciousness and even death. Avoid any areas or actions that expose you to carbon monoxide.

## Stopping The Engine

To stop the engine in an emergency, simply turn the engine switch to the **OFF** position. Under normal conditions, use the following procedure.

1. Move the throttle lever to the **SLOW** position. (Fig D)
2. Turn the engine switch to the **OFF** position. (Fig E)
3. Turn the fuel valve lever to the **OFF** position. (Fig F)

When the engine is not in use, leave the fuel valve lever in the **OFF** position to prevent the carburettor flooding and to reduce the possibility of fuel leakage.

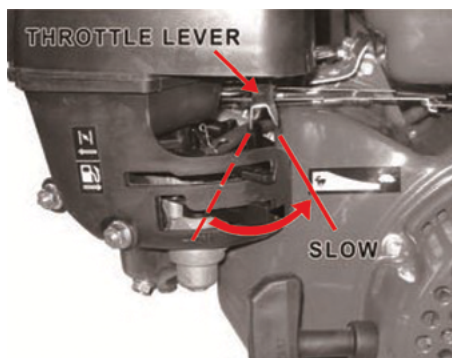

Fig D

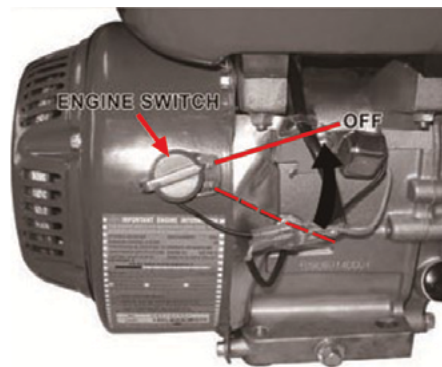

Fig E

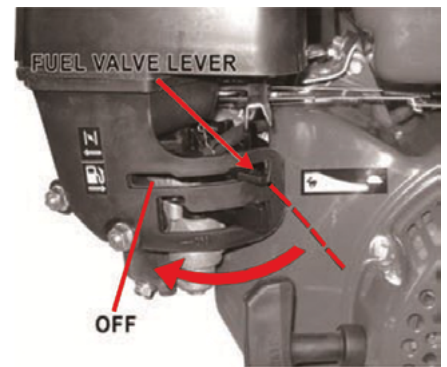

Fig F

# SERVICE & MAINTENANCE

## The Importance of Maintenance

Good maintenance is essential for safe, economical, and trouble-free operation. It will also help reduce air pollution.

### WARNING

- Improper maintenance on this engine, or failure to correct a problem before operation, can cause a malfunction in which you can be seriously hurt or killed.
- Always follow the inspection and maintenance recommendations and schedules in this owner's manual.

To help you properly care for your engine, the following pages include a maintenance schedule, routine inspection procedures, and simple maintenance procedures using basic hand tools. Other service tasks that are more difficult, or require special tools, are best handled by professionals and are normally performed by a qualified mechanic.

The maintenance schedule applies to normal operating conditions. If you operate your engine under unusual conditions, such as sustained high-load or high-temperature operation, or use in unusually wet or dusty conditions, consult your servicing dealer for recommendations applicable to your individual needs and use.

Maintenance, replacement or repair of emission control devices and systems may be done by any engine repair establishment or individual, using parts that are "certified" to EPA standards.

## Maintenance Safety

Some of the most important safety precautions are as follows. However, we cannot warn you of every conceivable hazard that can arise in performing maintenance. Only you can decide whether or not you should perform a given task.

## Safety Precautions

- Make sure the engine is **OFF** before you begin any maintenance or repairs. This will eliminate several potential hazards:
  - » Carbon monoxide poisoning from engine exhaust. Be sure there is adequate ventilation whenever you operate the engine.
  - » Burns from hot parts. Let the engine and exhaust system cool before touching.
  - » Injury from moving parts. **DO NOT** run the engine unless instructed to do so.
- Read the instructions before you begin, and make sure you have the tools and skills required.
- To reduce the possibility of fire or explosion, be careful when working around petrol. Use only a non-flammable solvent, not petrol, to clean parts. Keep cigarettes, sparks and flames away from all fuel-related parts.
- To ensure the best quality and reliability, use only new, genuine JD parts or their equivalents for repair and replacement.

# SERVICE & MAINTENANCE

## Maintenance Schedule

ITEM Perform at every indicated month or operating hour interval, whichever comes first		REGULAR SERVICE PERIOD (3)	Each use	First month / 20 hours	Every 3 months / 50 hours	Every 6 months / 100 hours	Every year / 300 hours	
●	Engine oil	Check level	○					
		Change		○		○		
●	Air filter	Check	○					
		Clean			○ (1)	○ *(1)		
		Replace					○**	
●	Sediment cup	Clean				○		
●	Spark plug	Check and adjust				○		
		Replace					○	
	Spark arrester (optional parts)	Clean				○		
●	Idle speed	Check and adjust					○ (2)	
●	Valve clearance	Check and adjust					○ (2)	
●	Combustion chamber	Clean	After every 500 hours (2)					
●	Fuel tank & filter	Clean				○ (2)		
●	Fuel tube	Check	Every 2 years (Replace if necessary) (2)					

● Emission-related items.

\* Internal vent carburettor with dual element type only.

\*\* Replace paper element type only. Cyclone type every 2 years or 600 hours.

(1) Service more frequently when used in dusty areas.

(2) These items should be serviced by your servicing dealer, unless you have the proper tools and are mechanically proficient.

(3) For commercial use, log hours of operation to determine proper maintenance intervals.

# SERVICE & MAINTENANCE

## Air Filter Inspection and Service

A dirty air filter will restrict air flow to the carburettor, reducing engine performance. If you operate the engine in very dusty areas, clean the air filter more often than specified in the MAINTENANCE SCHEDULE.

### NOTICE

Operating the engine without an air filter, or with a damaged air filter, will allow dirt to enter the engine, causing rapid engine wear. This type of damage is not covered by the Warranty.

## Dual-filter-Element Type

1. Remove the wing nut, and remove the air cleaner cover.
2. Carefully remove plastic grid from the bottom of the cover.
3. Carefully remove the foam air filter from the cover. Wash the filter in warm, soapy water, rinse, and allow to dry thoroughly.
4. Wipe dirt from the inside of the air cleaner base and cover, using a moist rag. Be careful to prevent dirt from entering the air duct that leads to the carburettor.
5. Insert the cleaned, dry or new foam air filter in the cover and replace plastic grid.
6. Reinstall the air cleaner assembly. Be sure the gasket is in place beneath the air filter.
7. Tighten the air filter wing nut securely.



## Sediment Cup Cleaning

1. Move the fuel valve to the OFF position, then remove the fuel sediment cup and O-ring.

### ! WARNING

Petrol is highly flammable and explosive. You can be burned or seriously injured when handling fuel.

- Stop the engine and keep heat, sparks and flames away
  - Handle fuel only outdoors
  - Wipe up spills immediately
2. Wash the sediment cup and O-ring in non-flammable solvent, and dry them thoroughly.
  3. Place the O-ring in the fuel valve, and install the sediment cup. Tighten the sediment cup securely.
  4. Move the fuel valve to the ON position, and check for leaks. Replace the O-ring if there is any leakage.

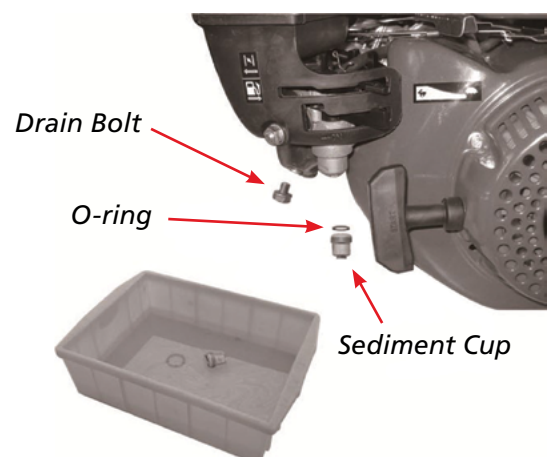

# SERVICE & MAINTENANCE

## Spark Plug Service

Recommended spark plugs: **BPR6ES (NGK)**, **W20EPR-U (DENSO)**

### NOTICE

An incorrect spark plug can cause engine damage.

1. Disconnect the spark plug cap, and remove any dirt from around the spark plug area.
2. Remove the spark plug with a 13/16-inch spark plug wrench.
3. Inspect the spark plug. Replace it if the electrodes are worn or heavy carbon build-up is found, or if the insulator is cracked or chipped.
4. Measure the spark plug electrode gap with a suitable gauge. The gap should be 0.028-0.031 in (0.70-0.80 mm). Correct the gap, if necessary, by carefully bending the side electrode.
5. Install the spark plug carefully, by hand, to avoid cross threading.
6. After the spark plug seats, tighten with a 13/16-inch spark plug wrench to compress the sealing washer.

If reinstalling the used spark plug, tighten 1/8—1/4 turn after the spark plug seats.

If installing a new spark plug, tighten 1/2 turn after the spark plug seats.

### NOTICE

A loose spark plug can overheat and damage the engine. Over tightening the spark plug can damage the threads in the cylinder head.

7. Attach the spark plug cap.

Spark plug Wrench

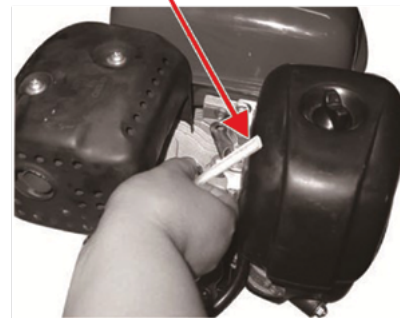

## Idle Speed Adjustment

1. Start the engine outdoors, and allow it to warm up to operating temperature.
2. Move the throttle lever to its slowest position.
3. Turn the throttle stop screw to obtain the standard idle speed. Standard idle speed: 1rpm

Throttle stop screw

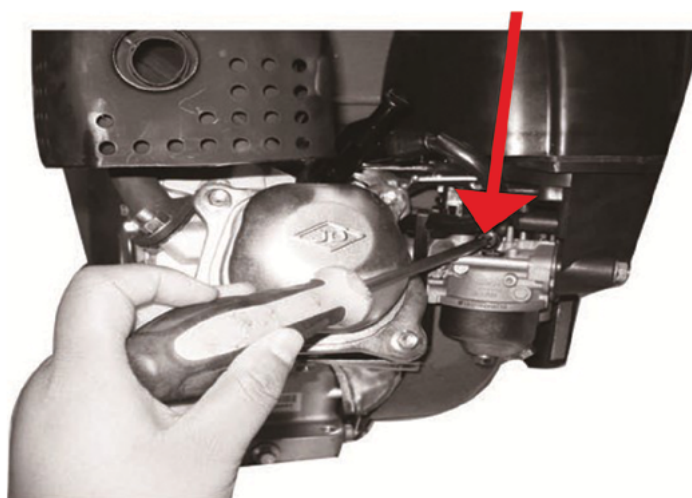



# TROUBLESHOOTING

## Engine will not start

		Possible cause	Correction
1.	Electric starting (applicable types): Check battery and fuse.	Discharged.	Recharge battery.
2.	Check control positions.	Fuel valve <b>OFF</b> .	Move valve lever to <b>ON</b> .
		Choke <b>OPEN</b> .	Move choke lever to <b>CLOSED</b> unless engine is warm.
		Engine switch <b>OFF</b> .	Turn engine switch to <b>ON</b> .
3.	Check fuel.	Out of fuel.	Refuel.
		Bad fuel; engine stored without treating or draining petrol, or refuelled with bad petrol.	Drain fuel tank and carburettor Refuel with fresh petrol.
4.	Remove and inspect spark plug.	Spark plug faulty, fouled, or improperly gapped.	Clean, gap, or replace spark plug.
		Spark plug wet with fuel (flooded engine).	Dry and reinstall spark plug. Start engine with throttle lever in <b>FAST</b> position.
5.	Take engine to an authorized JD servicing dealer, or refer to shop manual.	Fuel filter clogged, carburettor malfunction, ignition malfunction, valves stuck etc.	Replace or repair faulty components as necessary.

## Engine lacks power

		Possible cause	Correction
1.	Check air filter.	Filter element(s) clogged.	Clean or replace filter elements.
2.	Check fuel.	Bad fuel; engine stored without treating or draining petrol, or refuelled with bad petrol.	Drain fuel tank and carburettor. Refuel with fresh petrol.
3.	Take engine to an authorized JD servicing dealer, or refer to shop manual.	Fuel filter clogged, carburettor malfunction, ignition malfunction, valves stuck, etc.	Replace or repair faulty components as necessary.

# STORAGE

Proper storage preparation is essential for keeping your engines trouble free and looking good. The following steps will help to keep rust and corrosion from impairing your engine's function and appearance, and will make the engine easier to start after storage.

## Cleaning

If the engine has been running, allow it to cool for at least half an hour before cleaning. Clean all exterior surfaces, touch up any damaged paint, and coat other areas that may rust with a light film of oil.

### NOTICE

- Using a garden hose or pressure washing equipment can force water into the air cleaner or muffler opening. Water in the air cleaner will soak the air filter, and water that passes through the air filter or muffler can enter the cylinder, causing damage.
- Water contacting a hot engine can cause damage. If the engine has been running, allow it to cool for at least half an hour before washing.

## Fuel

Petrol will oxidise and deteriorate in storage. Old petrol will cause hard starting, and it leaves gum deposits that clog the fuel system. If the fuel in your engine deteriorates during storage, you may need to have the carburettor and other fuel system components serviced or replaced.

The length of time that petrol can be left in your fuel tank and carburettor without causing functional problems will vary with such factors as fuel blend, your storage temperatures, and whether the fuel tank is partially or completely filled. The air in a partially filled fuel tank promotes fuel deterioration. Very warm storage/temperatures accelerate fuel deterioration. Fuel deterioration problems may occur within a few months, or even less if the petrol was not fresh when you filled the fuel tank.

The Distributor's Limited Warranty does not cover fuel system damage or engine performance problems resulting from neglected storage preparation.

You can extend fuel storage life by adding a fuel stabilizer that is formulated for that purpose, or you can avoid fuel deterioration problems by draining the fuel tank and carburettor.

## Adding a Fuel Stabilizer to Extend Fuel Storage Life

When adding a fuel stabilizer, fill the fuel tank with fresh petrol. If only partially filled, air in the tank will promote fuel deterioration during storage. If you keep a container of petrol for refuelling, be sure that it contains only fresh petrol.

1. Add fuel stabilizer following the manufacturer's instructions.
2. After adding a fuel stabilizer, run the engine outdoors for 10 minutes to be sure that treated petrol has replaced the untreated petrol in the carburettor.
3. Stop the engine, and move the fuel valve lever to the **OFF** position.

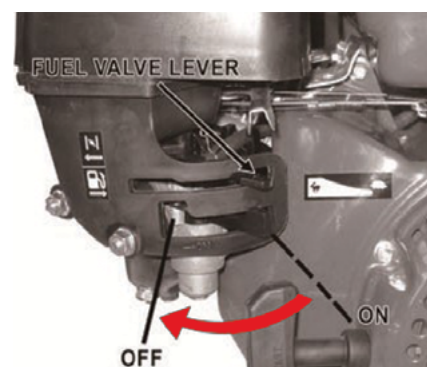

# STORAGE

## Draining the Fuel Tank and Carburettor

1. Place an approved fuel container below the carburettor, and use a funnel to avoid spilling fuel.
2. Remove the carburettor drain bolt and sediment cup, then move the fuel valve lever to the **ON** position.
3. After all the fuel has drained into the container, reinstall the drain bolt and sediment cup. Tighten them securely.

### **⚠ WARNING**

Petrol is highly flammable and explosive. You can be burned or seriously injured when handling fuel.

- Keep heat, sparks and flame away.
- Handle fuel only outdoors.
- Wipe up spills immediately.

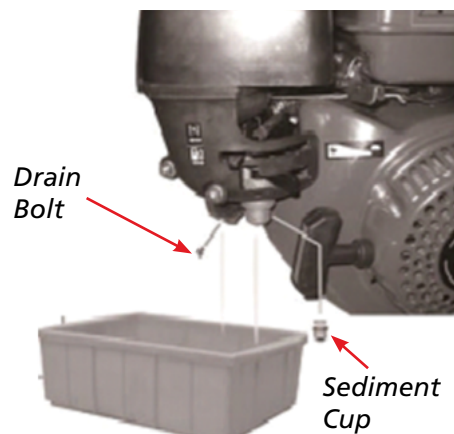

## Engine Oil

1. Change the engine oil.
2. Remove the spark plug.
3. Pour a tablespoon of clean engine oil into the cylinder.
4. Pull the starter rope several times to distribute the oil in the cylinder.
5. Reinstall the spark plug.
6. Pull the starter rope slowly until resistance is felt and the notch on the starter pulley aligns with the hole at the top of the recoil starter cover. This will close the valves so moisture cannot enter the engine cylinder. Return the starter rope gently.



## Storage Precautions

If your engine is being stored with petrol in the fuel tank and carburettor, it is important to reduce the hazard of fuel vapour ignition. Select a well-ventilated storage area away from any appliance that operates with a flame, such as a furnace, water heater, or clothes dryer. Also avoid any area with a spark producing electric motor, or where power tools are operated.

If possible, avoid storage areas with high humidity, because that promotes rust and corrosion.

Unless all fuel has been drained from the fuel tank, leave the fuel valve lever in the **OFF** position to reduce the possibility of fuel leakage.

Position the equipment so the engine is level. Tilting can cause fuel or oil leakage.

With the engine and exhaust system cool, cover the engine to keep out dust. A hot engine and exhaust system can ignite or melt some materials. Do not use sheet plastic as a dust cover. A nonporous cover will trap moisture around the engine, promoting rust and corrosion.

## Removal from Storage

Check your engine as described in the BEFORE OPERATION/ON.

If the fuel was drained during storage preparation, fill the tank with fresh petrol.

If you keep a container of petrol for refuelling, be sure that it contains only fresh petrol. Petrol oxidises and deteriorates over time, causing hard starting with engine.

If the cylinder was coated with oil during storage preparation, the engine may smoke briefly at start-up. This is normal.

## Transporting

If the engine has been running, allow it to cool for at least 15 minutes before loading the engine-powered equipment on the transport vehicle. A hot engine and exhaust system can burn you and can ignite some materials. Keep the engine level when transporting to reduce the possibility of fuel leakage. Turn the fuel valve lever to the **OFF** position.

# OPTIONAL

## Remote Control Linkage (Optional)

The throttle and choke control levers can be modified for optional cable attachment. The following illustrations show installation examples for a solid wire cable and for a flexible, braided wire cable. If using a flexible, braided wire cable, add a return spring as shown.

It is necessary to loosen the throttle lever friction nut when operating the throttle with a remote-mounted control.

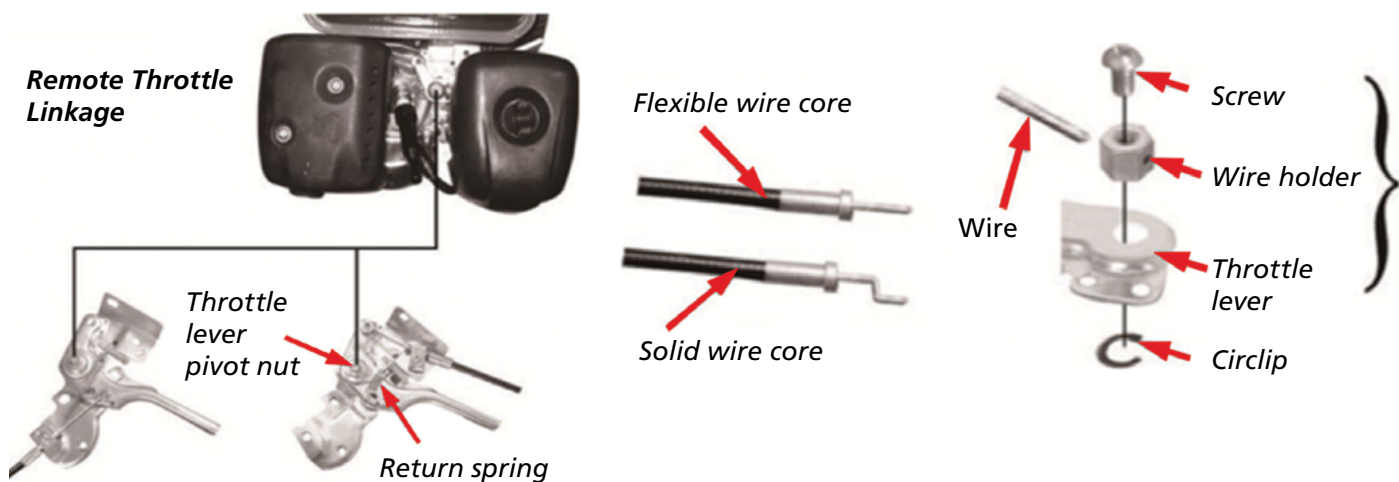

## Carburettor Modification for High Altitude Operation

At high altitude, the standard carburettor air-fuel mixture will be too rich. Performance will decrease, and fuel consumption will increase. A very rich mixture will also foul the spark plug and cause hard starting. Operation at an altitude that differs from that at which this engine was certified, for extended periods of time, may increase emissions.

High altitude performance can be improved by specific modifications to the carburettor. If you always operate your engine at altitudes above 5,000 feet (1,500 metres), have a qualified mechanic perform this carburettor modification. This engine, when operated at high altitude with the carburettor modifications for high altitude use, will meet each emission standard throughout its useful life.

Even with carburettor modification, engine horsepower will decrease about 3.5% for each 1,000 feet (300-metre) increase in altitude. The effect of altitude on horsepower will be greater than this if no carburettor modification is made.

### NOTICE

When the carburettor has been modified for high altitude operation, the air-fuel mixture will be too lean for low altitude use. Operation at altitudes below 5,000 feet (1,500 metres) with a modified carburettor may cause the engine to overheat and result in serious engine damage. For use at low altitudes, have a qualified mechanic rectum the carburettor to original factory specifications.

## Replacement Parts

We recommend the use of original replacement parts whenever you have maintenance done. These original-design replacement parts are manufactured to the same standards as the original parts, so you can be confident of their performance. The use of replacement parts that are not of the original design and quality may impair the effectiveness of your emission control system.

A manufacturer of an aftermarket part assumes the responsibility that the part will not adversely affect emission performance. The manufacturer or rebuilder of the part must certify that use of the part will not result in a failure of the engine to comply with emission regulations.

# TECHNICAL AND CONSUMER INFORMATION

## Wiring Diagrams

### Oil Sensor and Electric Starter Types

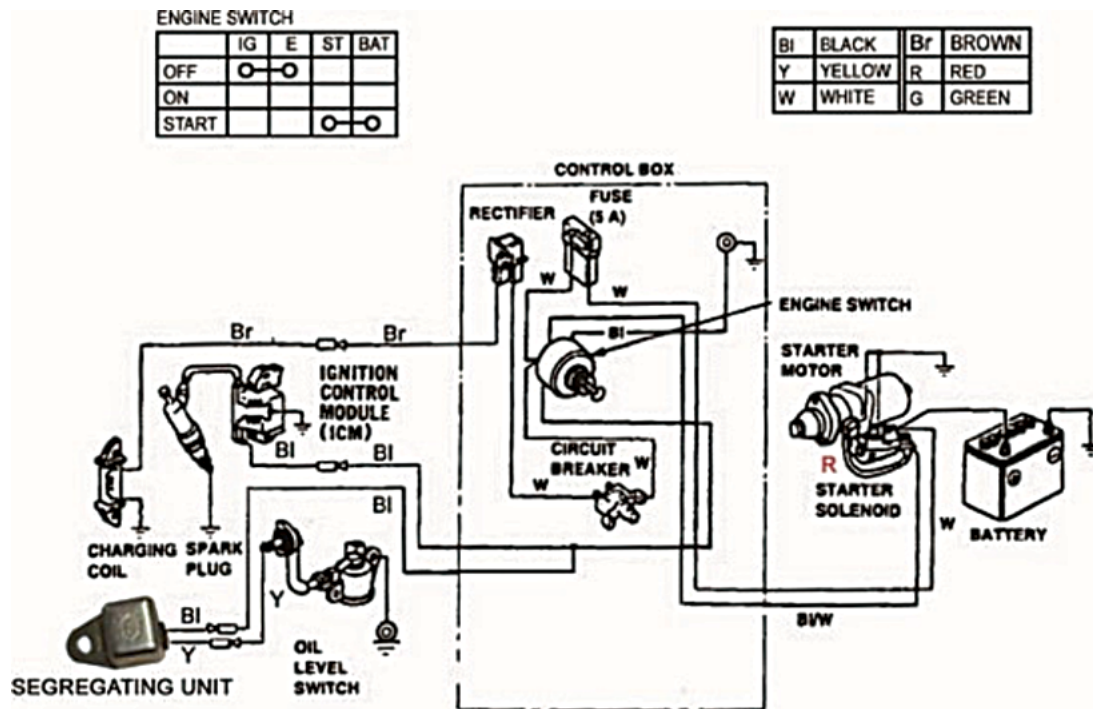

### Engine Types with Oil Sensor and without Electric Starter

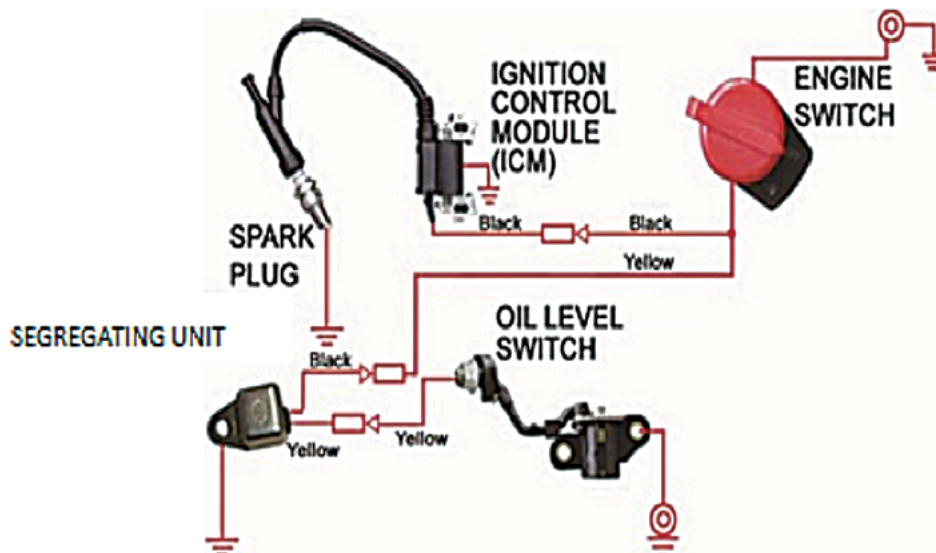

# SPECIFICATIONS

Model	JD-BE-6.5HP
Length x Width x Height	312 x 376 x 335 mm
Dry weight	16 kg
Engine type	4-stroke, 25°inclined, Single Cylinder Air-cooled
Displacement [Bore x Stroke]	68 x 54 [2.68 x 2.13]
Valve clearance	IN: 0.15+0.02mm cold EX: 0.20±0.02mm cold
Spark Plug	LD: F7RTC, NGK: aPR6ES
Spark plug gap	0.028 - 0.031in (0.70 - 0.80mm)
Idle speed	1400+150rpm
Max. Output	6.5HP at 3,600 rpm
Max. Torque	13 / 2500
Engine Oil	SAE 30
Engine Oil Capacity	0.6 Litres
Fuel	Unleaded 95 – 98 grade octane petrol
Fuel Tank Capacity	3.6 Litres
Fuel Consumption	290 g/HP-hour
Cooling System	Forced Air
Ignition System	Non-contact transistorized ignition (T.C.I.)
PTO Shaft Rotation	Counter clockwise

NOTE: Specifications may vary according to the types and are subject to change without notice.

# WARRANTY & SERVICE

## Warranties

Bigger Boyz Toyz offer a 1-year parts warranty on all products used for domestic use from the date of purchase. For all commercial use, a 3-month parts warranty period applies, unless specified in the item listing. All conditions below are based upon the product being faulty or not performing as described. In the instance where a return is required, the purchaser is liable for any shipping cost. Warranties will only be determined by a Bigger Boyz Toyz Technician upon inspection.

Warranties do not cover accidents, misuse, neglect, natural disaster or act of God or other external causes, or damage caused by operating the equipment in a manner that is not described in the instructions.

Our products come with guarantees that cannot be excluded under the Australian Consumer Law. You are entitled to a replacement or refund for a major failure and for compensation for any other reasonably foreseeable loss or damage. You are also entitled to have the goods repaired or replaced if the goods fail to be of acceptable quality and the failure does not amount to a major failure.

Parts purchases, consumable components and accessories such as chains, carry bags, batteries, hoses, grinding discs, covers, belts, cable, wheels and blades are not covered by standard warranty.

## Spare Parts

Spare parts are available. Please see our website ([www.bbta.com.au](http://www.bbta.com.au)) or contact us at [bbt@bbta.com.au](mailto:bbt@bbta.com.au) for more details.

# EXPLODED DIAGRAM & PARTS LIST

## 6.5HP ENGINE JF200

NO	SKU	DESCRIPTION	QTY
1	SP-JD-BE-6.5HP-001	HEAD COMP, CYLINDER	1
2	SP-JD-BE-6.5HP-002	GUIDE, IN. VALVE (OVERSIZE)	1
3	SP-JD-BE-6.5HP-003	GUIDE, VALVE (OVERSIZE)	1
4	SP-JD-BE-6.5HP-004	CLIP, VALVE GUIDE	2
5	SP-JD-BE-6.5HP-005	GASKET, CYLINDER HEAD	1
6	SP-JD-BE-6.5HP-006	COVER COMP, HEAD	1
7	SP-JD-BE-6.5HP-007	PACKING, HEAD COVER	1
8	SP-JD-BE-6.5HP-008	TUBE, BREATHER	1
9	SP-JD-BE-6.5HP-009	BOLT FLANGE 6X12	4
10	SP-JD-BE-6.5HP-010	BOLT, STUD, 6X109	2
11	SP-JD-BE-6.5HP-011	BOLT, STUD, 8X32	2
12	SP-JD-BE-6.5HP-012	PIN, DOWEL, 10X16	2
13	SP-JD-BE-6.5HP-013	BOLT, FLANGE, 8X60	4
14	SP-JD-BE-6.5HP-014	PLUG, SPARK (LD NGK)	1

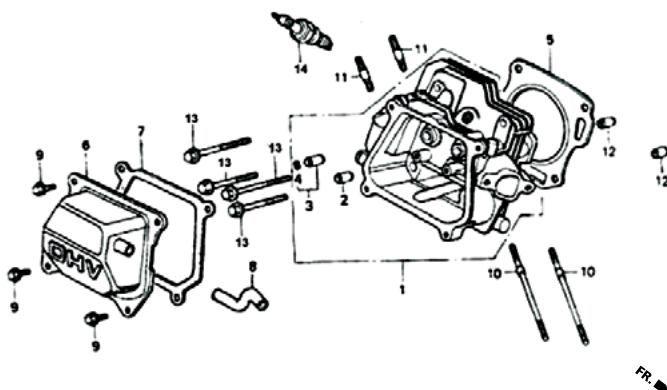

## CYLINDER BARREL. 1

NO	SKU	DESCRIPTION	QTY
1	SP-JD-BE-6.5HP-001.1	CYLINDER ASSY.	1
2	SP-JD-BE-6.5HP-002.1	SWITCH ASSY, OIL LEVEL	1
3	SP-JD-BE-6.5HP-003.1	GOVERNOR ASSY	1
4	SP-JD-BE-6.5HP-004.1	SLIDER, GOVERNOR	1
5	SP-JD-BE-6.5HP-005.1	SHAFT, GOVERNOR ARM	1
6	SP-JD-BE-6.5HP-006.1	PIN, LOCK, 8MM	1
7	SP-JD-BE-6.5HP-007.1	BOLT, FLANGE, 6X20	2
8	SP-JD-BE-6.5HP-008.1	BOLT, DRAINPLUG	2
9	SP-JD-BE-6.5HP-009.1	WASHER, THRUST, 6MM	1
10	SP-JD-BE-6.5HP-010.1	WASHER, DRAIN PLUG, 10.2MM	2
11	SP-JD-BE-6.5HP-011.1	CLIP, GOVERNOR HOLDER	1
12	SP-JD-BE-6.5HP-012.1	BEARING, RADIAL BALL 6205	2
13	SP-JD-BE-6.5HP-013.1	OIL SEAL, 25X41, 25X6	2
14	SP-JD-BE-6.5HP-014.1	O-RING, 14MM	1
15	SP-JD-BE-6.5HP-015.1	NUT, FLANGE 10MM	1
16	SP-JD-BE-6.5HP-016.1	WASHER, PLAIN, 6MM	1

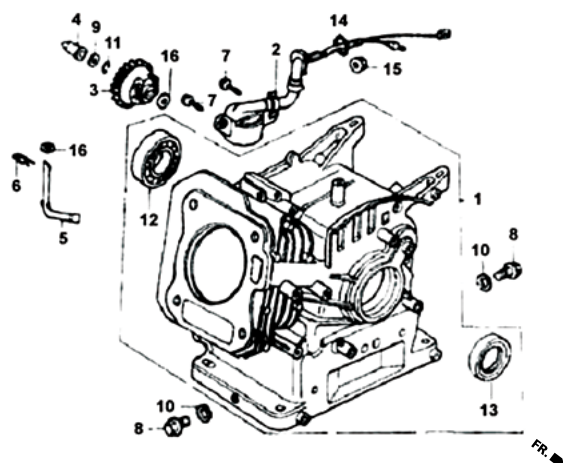

## CRANKCASE COVER. 2

NO	SKU	DESCRIPTION	QTY
1	SP-JD-BE-6.5HP-001.2	COVER ASSY, CRANKCASE	1
2	SP-JD-BE-6.5HP-002.2	COVER ASSY, CRANKCASE	1
3	SP-JD-BE-6.5HP-003.2	PACKING, CASE COVER	1
4	SP-JD-BE-6.5HP-004.2	CAP ASSY, OIL FILLER	1
5	SP-JD-BE-6.5HP-005.2	CAP ASSY, OIL FILLER	1
6	SP-JD-BE-6.5HP-006.2	CAP ASSY, OIL FILLER	1
7	SP-JD-BE-6.5HP-007.2	GASKET, OIL FILLER CAP	1
8	SP-JD-BE-6.5HP-008.2	GASKET, OIL FILLER CAP	2
9	SP-JD-BE-6.5HP-009.2	OIL SEAL, 25X41, 25X6	1
10	SP-JD-BE-6.5HP-010.2	PIN, DOWEL, 8X14	2
11	SP-JD-BE-6.5HP-011.2	BOLT, FLANGE, 8X32	6
12	SP-JD-BE-6.5HP-012.2	BEARING, RADIAL BALL, 6205	1
13	SP-JD-BE-6.5HP-013.2	COVER ASSY, CRANKCASE	1
14	SP-JD-BE-6.5HP-014.2	BEARING, RADIAL BALL, 6205	1

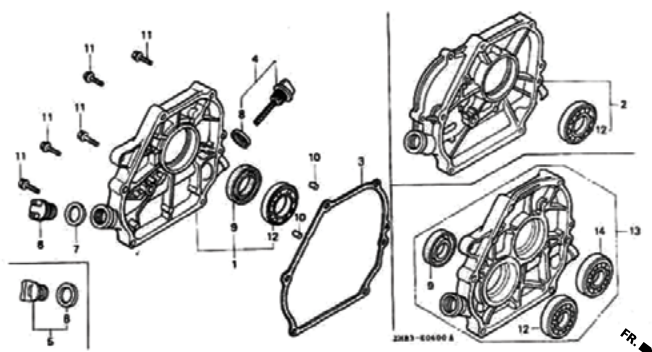



# EXPLODED DIAGRAM & PARTS LIST

## CRANKCASE. 3

NO	SKU	DESCRIPTION	QTY
1	SP-JD-BE-6.5HP-001.3	CRANKSHAFT COMP	1
2	SP-JD-BE-6.5HP-002.3	KEY, 5X5X30	1
3	SP-JD-BE-6.5HP-003.3	KEY, SPECIAL WOODRUFF	1

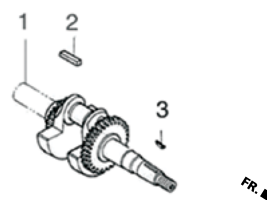

## PISTON. 4

NO	SKU	DESCRIPTION	QTY
1	SP-JD-BE-6.5HP-001.4	RING SET, PISTON (STD.)	1
2	SP-JD-BE-6.5HP-002.4	PISTON (STD.)	1
3	SP-JD-BE-6.5HP-003.4	PIN, PISTON	1
4	SP-JD-BE-6.5HP-004.4	ROD ASSY, CONNECTING (STD.)	1
5	SP-JD-BE-6.5HP-005.4	BOLT, CONNECTION ROD	2
6	SP-JD-BE-6.5HP-006.4	CLIP, PISTON PIN, 18 mm	2

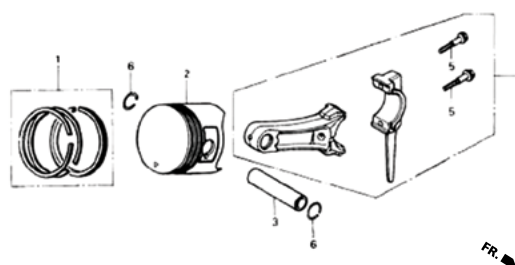

## CAMSHAFT.5

NO	SKU	DESCRIPTION	QTY
1	SP-JD-BE-6.5HP-001.5	CAMSHAFT ASSY	1
2	SP-JD-BE-6.5HP-002.5	ROD, PUSH	2
3	SP-JD-BE-6.5HP-003.5	ARM, VALVE ROCKER	2
4	SP-JD-BE-6.5HP-004.5	LIFTER, VALVE	2
5	SP-JD-BE-6.5HP-005.5	PIVOT, ROCKER ARM	2
6	SP-JD-BE-6.5HP-006.5	SPRING, WEIGHT RETURN	1
7	SP-JD-BE-6.5HP-007.5	VALVE, IN.	1
8	SP-JD-BE-6.5HP-008.5	VALVE, EX.	1
9	SP-JD-BE-6.5HP-009.5	SPRING, VALVE	2
10	SP-JD-BE-6.5HP-010.5	RETAINER, IN. VALVE SPRING	1
11	SP-JD-BE-6.5HP-011.5	RETAINER, EX. VALVE SPRING	1
12	SP-JD-BE-6.5HP-012.5	ROTATOR, VALVE	1
13	SP-JD-BE-6.5HP-013.5	PLATE, PUSH ROD GUIDE	1
14	SP-JD-BE-6.5HP-014.5	BOLT, PIVOT 8 mm	2
15	SP-JD-BE-6.5HP-015.5	NUT, PIVOT ADJUSTING	2
16	SP-JD-BE-6.5HP-016.5	CAMSHAFT ASSY	1

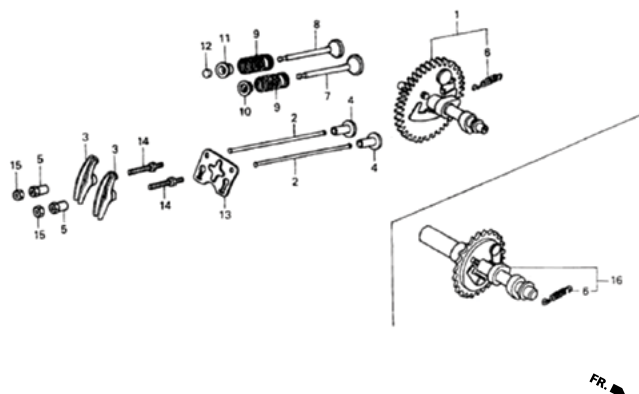

## RECOIL STARTER.6

NO	SKU	DESCRIPTION	QTY
1	SP-JD-BE-6.5HP-001.6	CAMSHAFT ASSY	1
2	SP-JD-BE-6.5HP-002.6	ROD, PUSH	2
3	SP-JD-BE-6.5HP-003.6	ARM, VALVE ROCKER	2
4	SP-JD-BE-6.5HP-004.6	LIFTER, VALVE	2
5	SP-JD-BE-6.5HP-005.6	PIVOT, ROCKER ARM	2
6	SP-JD-BE-6.5HP-006.6	SPRING, WEIGHT RETURN	1
7	SP-JD-BE-6.5HP-007.6	VALVE, IN.	1
8	SP-JD-BE-6.5HP-008.6	VALVE, EX.	1
9	SP-JD-BE-6.5HP-009.6	VALVE SPRING	2
10	SP-JD-BE-6.5HP-010.6	RETAINER, IN. VALVE SPRING	1
11	SP-JD-BE-6.5HP-011.6	RETAINER, EX. VALVE SPRING	1
12	SP-JD-BE-6.5HP-012.6	ROTATOR, VALVE	1
13	SP-JD-BE-6.5HP-013.6	PLATE, PUSH ROD GUIDE	1

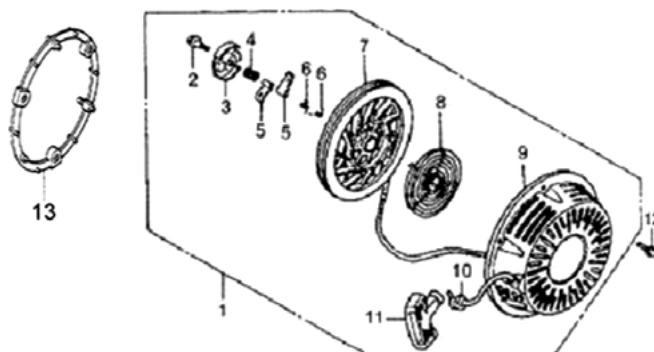

# EXPLODED DIAGRAM & PARTS LIST

## FAN COVER. 7

NO	SKU	DESCRIPTION	QTY
1	JD-BE-6.5HP-001.7	COVER COMP, FAN	1
2	JD-BE-6.5HP-002.7	PLATE, SIDE (STD)	1
3	JD-BE-6.5HP-003.7	CLAMPER, CORD	1
4	JD-BE-6.5HP-004.7	SHROUD COMP	1
5	JD-BE-6.5HP-005.7	SUB-HARNESS	1
6	JD-BE-6.5HP-006.7	SWITCH ASSY, ENGINE STOP	1
7	JD-BE-6.5HP-007.7	WIRE, STOP SWITCH	1
8	JD-BE-6.5HP-008.7	BOLT, FLANGE, 6X12	6
9	JD-BE-6.5HP-009.7	BOLT, FLANGE, 6X16	1

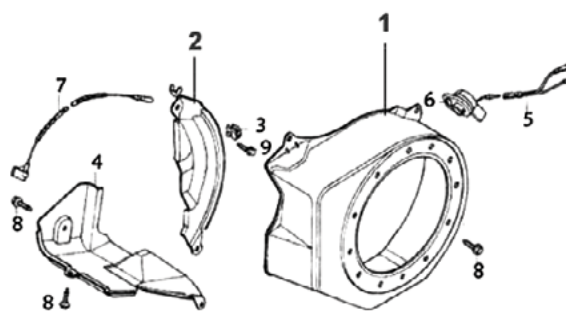

## CARBURETTOR. 8

NO	SKU	DESCRIPTION	QTY
1	JD-BE-6.5HP-001.8	GASKET, INSULATOR	1
2	JD-BE-6.5HP-002.8	INSULATOR, CARBURETTOR	1
3	JD-BE-6.5HP-003.8	GASKET, CARBURETTOR	1
4	JD-BE-6.5HP-004.8	CARBURETTOR	1
5	JD-BE-6.5HP-005.8	SPACER COMP, CARBURETTOR	1
6	JD-BE-6.5HP-006.8	LEVER COMP, CHOKE (STD)	1

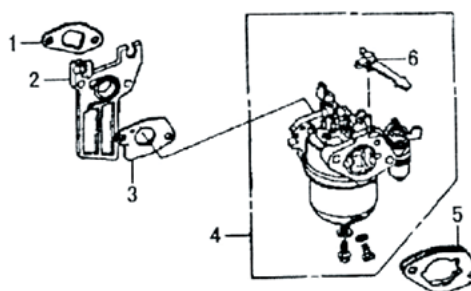

## AIR CLEANER. 9

NO	SKU	DESCRIPTION	QTY
1	JD-BE-6.5HP-001.9	FILTER, OUTER	1
2	JD-BE-6.5HP-002.9	PRINCIPAL PART, AIR CLEANER	1
3	JD-BE-6.5HP-003.9	CASE COMP, AIR CLEANER	1
4	JD-BE-6.5HP-004.9	COVER, AIR CLEANER	1
5	JD-BE-6.5HP-005.9	STAY, AIR CLEANER	1
6	JD-BE-6.5HP-006.9	SEAL, AIR CLEANER	1
7	JD-BE-6.5HP-007.9	BOLT, WINKER SETTING	1
8	JD-BE-6.5HP-008.9	NUT, FLANGE, 6MM	1
9	JD-BE-6.5HP-009.9	BOLT, FLANGE, 6X10	1

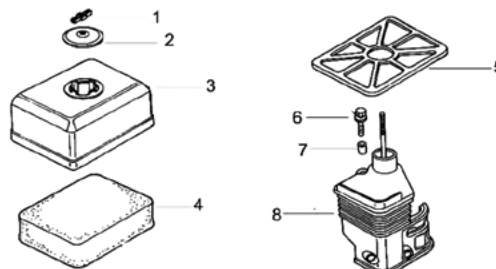

## AIR CLEANER. 10

NO	SKU	DESCRIPTION	QTY
1	JD-BE-6.5HP-001.10	GASKET, ELBOW	1
2	JD-BE-6.5HP-002.10	ELEMENT, AIR CLEANER (DUAL)	1
3	JD-BE-6.5HP-003.10	FILTER, OUTER	1
4	JD-BE-6.5HP-004.10	COVER, AIR CLEANER (DUAL)	1
5	JD-BE-6.5HP-005.10	GROMMET, AIR CLEANER	1
6	JD-BE-6.5HP-006.10	NOSE, SILENCER	1
7	JD-BE-6.5HP-007.10	COLLAR, AIR CLEANER	2
8	JD-BE-6.5HP-008.10	COLLAR B, AIR CLEANER	1
9	JD-BE-6.5HP-009.10	ELBOW COMP, AIR CLEANER	1
10	JD-BE-6.5HP-010.10	WINGNUT, AIR CLEANER COVER	1
11	JD-BE-6.5HP-011.10	WINGNUT, TOOL BOX SETTING	1
12	JD-BE-6.5HP-012.10	BOLT-WASHER, 6X20	1
13	JD-BE-6.5HP-013.10	NUT, FLANGE, 6MM	2

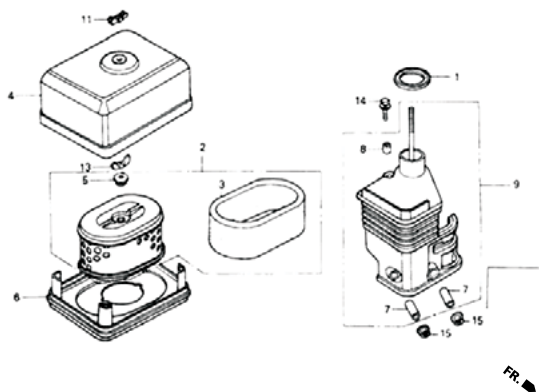

# EXPLODED DIAGRAM & PARTS LIST

## AIR CLEANER. 11

NO	SKU	DESCRIPTION	QTY
1	JD-BE-6.5HP-001.11	FILTER, OUTER	1
2	JD-BE-6.5HP-002.11	PRINCIPAL PART, AIR CLEANER	1
3	JD-BE-6.5HP-003.11	CASE COMP, AIR CLEANER	1
4	JD-BE-6.5HP-004.11	COVER, AIR CLEANER	1
5	JD-BE-6.5HP-005.11	STAY, AIR CLEANER	1
6	JD-BE-6.5HP-006.11	SEAL, AIR CLEANER	1
7	JD-BE-6.5HP-007.11	BOLT, WINKER SETTING	4
8	JD-BE-6.5HP-008.11	NUT, FLANGE, 6MM	4
9	JD-BE-6.5HP-009.11	BOLT, FLANGE, 6X10	2

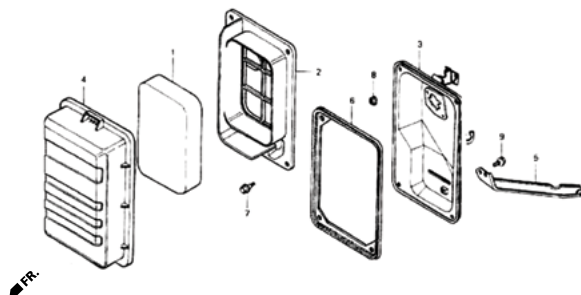

## MUFFLER. 12

NO	SKU	DESCRIPTION	QTY
1	JD-BE-6.5HP-001.12	MUFFLER COMP	1
2	JD-BE-6.5HP-002.12	PROTECT, MUFFLER OUTER	1
3	JD-BE-6.5HP-003.12	ARRESTER, SPARK	1
4	JD-BE-6.5HP-004.12	GASKET, MUFFLER	1
5	JD-BE-6.5HP-005.12	SCREW, TAPPING, 5X8	4
6	JD-BE-6.5HP-006.12	PROTECT, MUFFLER OUTER	1

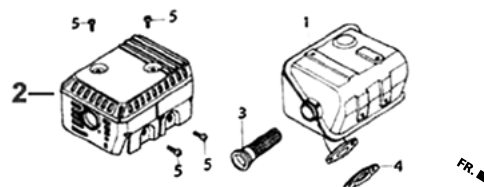

## FUEL TANK. 13

NO	SKU	DESCRIPTION	QTY
1	JD-BE-6.5HP-001.13	TANK COMP, FUEL	1
2	JD-BE-6.5HP-002.13	CAP COMP, FUEL FILLER	1
3	JD-BE-6.5HP-003.13	NUT, FLANGE, 6MM	2
4	JD-BE-6.5HP-004.13	CLIP, TUBE	1
5	JD-BE-6.5HP-005.13	BULK HOSE FUEL	1
6	JD-BE-6.5HP-006.13	RUBBER, SUPPORTER	1
7	JD-BE-6.5HP-007.13	BOLT, FLANGE, 6X25	1
8	JD-BE-6.5HP-008.13	JOINT, FUEL TANK	1
9	JD-BE-6.5HP-009.13	O-RING	1
10	JD-BE-6.5HP-010.13	FILTER, FUEL	1

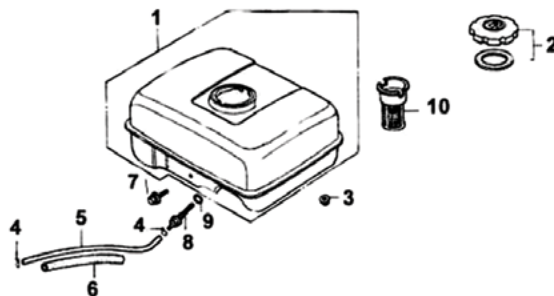

## FLY WHEEL. 14

NO	SKU	DESCRIPTION	QTY
1	JD-BE-6.5HP-001.14	FLYWHEEL COMP	1
2	JD-BE-6.5HP-002.14	FLYWHEEL COMP (LAMP)	1
3	JD-BE-6.5HP-003.14	FAN, COOLING	1
4	JD-BE-6.5HP-004.14	PULLEY, STARTER	1
5	JD-BE-6.5HP-005.14	NUT, SPECIAL	1
6	JD-BE-6.5HP-006.14	COIL ASSY, IGNITION	1
7	JD-BE-6.5HP-007.14	BOLT, FLANGE	

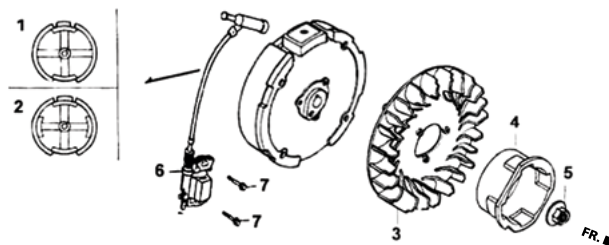

# EXPLODED DIAGRAM & PARTS LIST

## CONTROL. 15

NO	SKU	DESCRIPTION	QTY
1	JD-BE-6.5HP-001.15	CONTROL ASSY (STD)	1
2	JD-BE-6.5HP-002.15	CONTROL ASSY (REMOTE)	1
3	JD-BE-6.5HP-003.15	CONTROL ASSY (CYCLONE)	1
4	JD-BE-6.5HP-004.15	ARM, GOVERNOR	1
5	JD-BE-6.5HP-005.15	ROD, GOVERNOR	1
6	JD-BE-6.5HP-006.15	SPRING, GOVERNOR	1
7	JD-BE-6.5HP-007.15	SPRING, THROTTLE RETURN	1
8	JD-BE-6.5HP-008.15	CONTROL ASSY	1
9	JD-BE-6.5HP-009.15	LEVER, CONTROL	1
10	JD-BE-6.5HP-010.15	SPRING, LEVER	1
11	JD-BE-6.5HP-011.15	WASHER, CONTROL LEVER	1
12	JD-BE-6.5HP-012.15	HOLDER, CABLE	1
13	JD-BE-6.5HP-013.15	SPACER, CONTROL LEVER	1
14	JD-BE-6.5HP-014.15	BASE COMP, CONTROL	1
15	JD-BE-6.5HP-015.15	SPRING, CONTROL ADJUSTING	1
16	JD-BE-6.5HP-016.15	SPRING, CABLE RETURN	1
17	JD-BE-6.5HP-017.15	HOLDER, WIRE	1
18	JD-BE-6.5HP-018.15	BOLT, FLANGE	2
19	JD-BE-6.5HP-019.15	BOLT, GOVERNOR ARM	1
20	JD-BE-6.5HP-020.15	NUT, SELF-LOCK (6MM)	1
21	JD-BE-6.5HP-021.15	CIRCLIP (5MM)	1
22	JD-BE-6.5HP-022.15	SCREW, PAN 4X6	1
23	JD-BE-6.5HP-023.15	SCREW, PAN 5X25	1
24	JD-BE-6.5HP-024.15	SCREW, PAN 5X16	1
25	JD-BE-6.5HP-025.15	NUT, FLANGE (6MM)	1

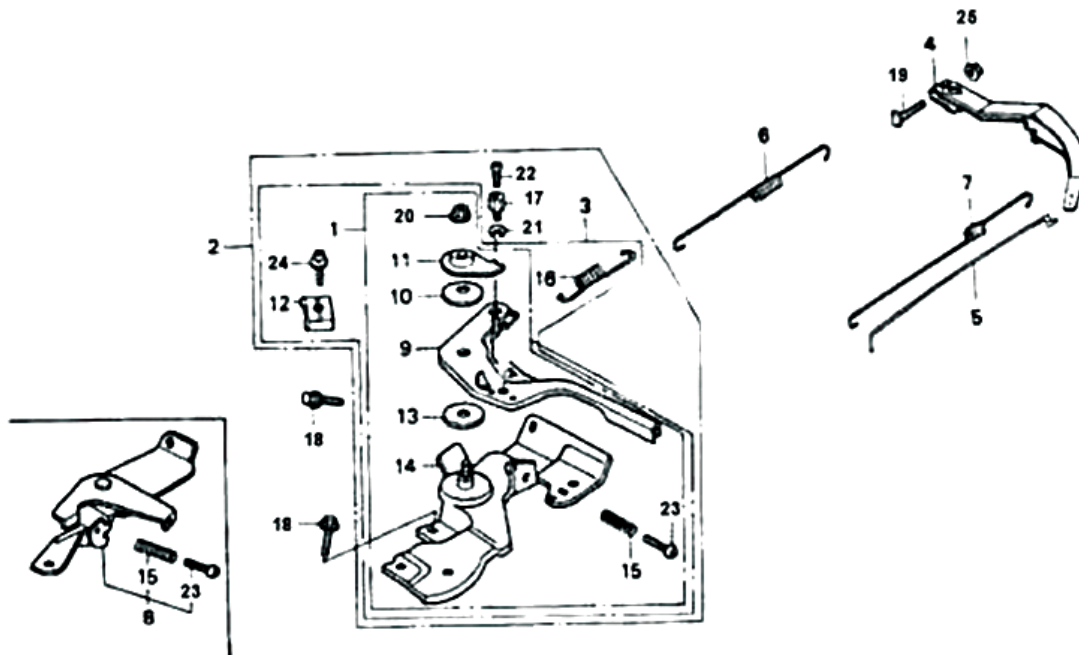

## YOU MAY ALSO LIKE



Chainsaws



Cultivators / Tillers



Log Splitters



Mulcher

Enquiry or problems with our products?

**CALL US (02) 4257 4787**



**[www.bbta.com.au](http://www.bbta.com.au)**

COPYRIGHT © BIGGER BOYZ TOYZ AUSTRALIA PTY LTD  
Unit 2/3 Delta Place, Albion Park Rail NSW 2527  
JD-BE-6.5HP-MNL1902