

# OWNER'S MANUAL

## 40cc Chainsaw



# OWNER'S MANUAL

Assembly & Operating Instructions

## BBT 40cc Chainsaw

MODEL NO. BT-CS-40



---

## To The Owner

---

Thank You!

Thank you for purchasing our Chainsaw. It was carefully engineered to provide excellent performance when properly operated and maintained.

Please read this entire manual prior to operating the chainsaw. It instructs you how to safely and easily set up, operate and maintain your chainsaw. Please be sure that you, and any other persons who will operate the chainsaw, carefully follow the recommended safety practices at all times. Failure to do so could result in personal injury or property damage.

All information in this manual is relative to the most recent product information available at the time of printing. Review this manual frequently to familiarize yourself with the machine, its features and operation. Please be aware that this Owner's Manual may cover a range of product specifications for various models. Characteristics and features discussed and/or illustrated in this manual may not be applicable to all models. We reserve the right to change product specifications, designs and equipment without notice and without incurring obligation.

All the power testing information used to establish the power rating of the engine equipped on these chainsaws can be found at the engine manufacturer's manual or website. If you have any problems or questions concerning the machine, contact our Customer Support Department.

Throughout this manual, all references to right and left side of the chainsaw are observed from the operating position. The engine manufacturer is responsible for all engine-related issues with regards to performance, power-rating, specifications, warranty and service. Please refer to the engine manufacturer's Owner's Manual packed separately with your chainsaw for more information.

---

## Customer Support

---

*Please do NOT return the chainsaw without first contacting the Customer Support Department at [bbt@bbta.com.au](mailto:bbt@bbta.com.au).*

If you have difficulty assembling this product or have any questions regarding the controls, operation, or maintenance of this chainsaw, please contact our Customer Support Department.

**SAVE THESE INSTRUCTIONS**

# TABLE OF CONTENTS

	Page(s)		Page(s)
To The Owner.....	2	General rules.....	21
Customer Support.....	2	Basic cutting techniques.....	22
<b>TABLE OF CONTENTS .....</b>	<b>3</b>	Limbing.....	22
<b>IMPORTANT SAFETY INFORMATION .....</b>	<b>4-5</b>	Cutting.....	22
Key to symbols .....	5	Tree felling technique.....	23
<b>WHAT IS WHAT?.....</b>	<b>6</b>	Felling .....	24
<b>GENERAL SAFETY PRECAUTIONS.....</b>	<b>7-14</b>	Freeing a tree that has fallen badly .....	25
Before using a new chainsaw.....	7	Cutting trees and branches that are in tension .....	25
Always use common sense .....	7	How to avoid kickback .....	26
Personal protective equipment.....	8	Limbing.....	26
Chainsaw's safety equipment.....	8	Cutting the trunk into logs .....	26
Chain brake and front hand guard.....	8	<b>MAINTENANCE .....</b>	<b>27-32</b>
Throttle lock.....	9	General .....	27
Chain catcher .....	10	Function.....	27
Right hand guard.....	10	Basic settings and running in .....	27
Vibration damping system .....	10	Fine adjustment .....	27
Stop switch .....	10	Conditions .....	27
Muffler .....	10	Low speed jet L .....	27
Cutting equipment .....	10	Fine adjustment of the idling speed T.....	27
General rules.....	10	High speed jet H .....	27
Cutting equipment designed to reduce kickback.....	11	Correctly adjusted carburettor.....	28
Sharpening your chain and		Checking, maintaining and	
adjusting depth gauge setting.....	12	servicing chainsaw safety equipment.....	28
Lubricating cutting equipment.....	13	Chain brake and front hand guard.....	28
Chain oil .....	13	Checking the inertia brake release.....	28
Filling with chain oil .....	13	Checking the brake trigger .....	28
Checking chain lubrication.....	13	Throttle lock.....	28
Chain drive sprocket.....	14	Chain catcher .....	29
Needle bearing lubrication .....	14	Right hand guard.....	29
Checking wear on cutting equipment.....	14	Vibration damping system .....	29
<b>ASSEMBLY.....</b>	<b>15</b>	Stop switch .....	29
Fitting the bar and chain.....	15	Muffler .....	29
<b>FUEL HANDLING .....</b>	<b>16-17</b>	Starter.....	29
Fuel .....	16	Changing a broken or worn starter cord .....	29
Two-stroke oil.....	16	Tensioning the recoil spring.....	30
Mixing.....	16	Changing a broken recoil spring.....	30
Chain oil .....	16	Fitting the starter.....	30
Fuelling.....	17	Air filter .....	30
Fuel safety .....	17	Spark plug .....	30
Transport and storage .....	17	Lubricating the bar tip sprocket .....	31
Long-term storage .....	17	Needle bearing lubrication .....	31
<b>STARTING AND STOPPING .....</b>	<b>18-19</b>	Adjustment of the oil pump.....	31
Starting engine .....	18	Cooling system .....	31
Stopping.....	19	"Air Injection" centrifugal cleaning.....	31
Carburettor anti-freeze mechanism .....	19	Maintenance schedule.....	32
How to switch between operating modes.....	19	<b>TROUBLESHOOTING.....</b>	<b>34</b>
<b>WORKING TECHNIQUES.....</b>	<b>20-26</b>	<b>SPECIFICATIONS.....</b>	<b>35</b>
Before use .....	20	<b>WARRANTY &amp; SERVICE .....</b>	<b>36</b>
General working instructions.....	20	Warranties.....	36
Basic safety rules .....	20	Spare Parts.....	36
		<b>EXPLODED DIAGRAM &amp; PARTS LIST.....</b>	<b>37-39</b>



## IMPORTANT SAFETY INFORMATION



**WARNING:** Read and thoroughly understand all instructions in this manual and on the safety decals before assembling or operating this chainsaw. Failure to do so may cause serious injury or death. Do not allow anyone to operate this chainsaw who has not read this manual. As with all power equipment, a chainsaw can be dangerous if assembled or used improperly. Do not operate this chainsaw if you have any questions concerning its safe operation. To get answers to any questions, call our Customer Support Department.



This **SAFETY ALERT SYMBOL** identifies important safety messages in this manual. Failure to follow this important safety information may result in serious injury or death.



**DANGER!** This chainsaw was built to be operated according to the safe operation practices in this manual. As with any type of power equipment, carelessness or error on the part of the operator can result in serious injury. This chainsaw is capable of amputating hands and feet and throwing debris. Failure to observe the following safety instructions could result in serious injury or death.

The following signals words and meanings are intended to explain the levels of risk associated with this product.



**DANGER** indicates a hazardous situation which, if not followed, will result in serious injury or death.



**WARNING** indicates a hazardous situation which, if not avoided, could result in serious injury or death.



**CAUTION** indicates a hazardous situation which, if not avoided, could result in minor or moderate injury.

**NOTICE**

**NOTICE** is important information about the proper use of your chainsaw. Failure to follow this instruction could result in damage to your chainsaw or property.



# IMPORTANT SAFETY INFORMATION

## Key to symbols

Symbol	Description
	<b>READ THE OWNER'S MANUAL(S)</b> Read, understand and follow all instructions in the manual(s) before attempting to assemble and operate.
	<b>FACE PROTECTION</b> Always wear safety goggles or safety glasses with side shields, or a face shield when operating this product as well as ear protection.
	<b>WEAR GLOVES</b> Always wear nonslip, heavy-duty protective gloves when operating this product.
	<b>WEAR SAFETY FOOTWEAR</b> Always wear nonslip steel-toed safety footwear when operating this product.
	<b>TWO HANDS OPERATION</b> Both of the operator's hands must be used to operate the chainsaw. Never operate a chainsaw holding it with one hand only.
	<b>WARNING—KICKBACK</b> Tip contact may cause the guide bar to move suddenly upward and backward (kickback), which may cause serious injury.
	<b>STOP—SWITCH OFF BEFORE CARRYING</b> Switch off the engine by moving the stop switch to the STOP position before carrying out any checks or maintenance.
	<b>CHAIN BRAKE</b> The chain brake must be engaged when the chainsaw is started.
	<b>REFILL THE 2 STROKE MIXTURE</b> Petrol and oil mixture.
	<b>REFILL THE CHAIN OIL</b>
	<b>CHOKE</b> Pulling out the choke knob, the choke closes. Pushing in the choke knob, the choke opens.
	<b>CHAIN OILER ADJUSTMENT</b> " - " direction the oil flow decreases " + " direction the oil flow increases
	<b>CARBURETTOR ADJUSTMENT</b> H: High speed mixture L: Low speed mixture T: Idle speed

# WHAT IS WHAT?

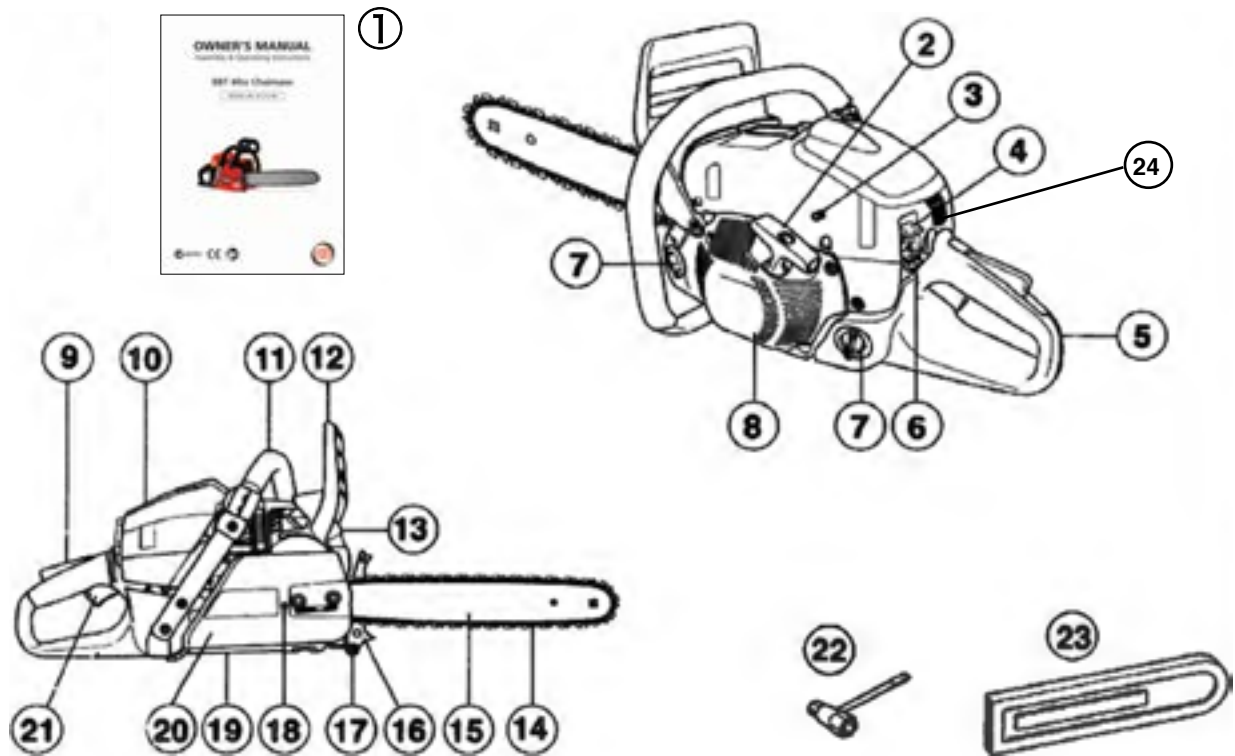

- |  |                                 |
|--|---------------------------------|
| 1. Owner's manual                        | 13. Muffler                     |
| 2. Starter handle                        | 14. Chain                       |
| 3. Adjuster screws, carburettor          | 15. Bar                         |
| 4. Stop switch (Ignition on/off switch.) | 16. Bumper spike                |
| 5. Rear handle                           | 17. Chain catcher               |
| 6. Choke control/Start throttle lock     | 18. Chain tensioning screw      |
| 7. Fuel tank                             | 19. Oil pump adjustment screw   |
| 8. Starter                               | 20. Clutch cover                |
| 9. Throttle lock                         | 21. Throttle control            |
| 10. Cylinder cover                       | 22. Combination spanner         |
| 11. Front handle                         | 23. Bar guard                   |
| 12. Front hand guard                     | 24. Primer bulb (if applicable) |

# GENERAL SAFETY PRECAUTIONS

## Before using a new chainsaw

- Please read this manual carefully.
- Check that the cutting equipment is correctly fitted and adjusted. See instructions under *Assembly*.
- Refuel and start the chainsaw. See instructions under *Fuel Handling and Starting and Stopping*.
- Do not use the chainsaw until sufficient chain oil has reached the chain. See instructions under *Lubricating cutting equipment*.
- Long-term exposure to noise can result in permanent hearing impairment. So always use approved hearing protection.



**WARNING!** Under no circumstances may the design of the chainsaw be modified without the express permission of the manufacturer. Always use genuine accessories. Non-authorized modifications and/or accessories can result in serious personal injury or the death of the operator or others. Your warranty may not cover damage or liability caused by the use of non-authorized accessories or replacement parts.



**WARNING!** A chainsaw is a dangerous tool if used carelessly or incorrectly and can cause serious, even fatal injuries. It is very important that you read and understand the contents of this owner's manual.



**WARNING!** The inside of the muffler contains chemicals that may be carcinogenic. Avoid contact with these elements in the event of a damaged muffler.



**WARNING!** Long-term inhalation of the engine's exhaust fumes, chain oil mist and dust from sawdust can represent a health risk.

## IMPORTANT!

The chainsaw is only designed for cutting wood.

You should only use the chainsaw with the bar and chain combinations we recommend in the *Specifications*.

Never use the chainsaw if you are fatigued, while under the influence of alcohol or drugs, medication or anything that could affect your vision, alertness, coordination or judgement.

Wear personal protective equipment. See instructions under *Personal protective equipment*.

Do not modify this product or use it if it appears to have been modified by others.

Never use a chainsaw that is faulty. Carry out all checks, maintenance and service instructions described in this manual. Some maintenance and service measures must be carried out by trained and qualified specialists. See instructions under *Maintenance*.

Never use any accessories other than those recommended in this manual. See instructions under *Cutting equipment and Specifications*.

**CAUTION!** Always wear protective glasses or a face visor to reduce the risk of injury from thrown objects. A chainsaw is capable of throwing objects, such as wood chips, small pieces of wood, etc., at great force. This can result in serious injury, especially to the eyes.



**WARNING!** Running an engine in a confined or badly ventilated area can result in death due to asphyxiation or carbon monoxide poisoning.



**WARNING!** Faulty cutting equipment or the wrong combination of bar and saw chain increases the risk of kickback! Only use the bar/saw chain combinations we recommend, and follow the filing instructions. See instructions under *Specifications*

## Always use common sense

It is not possible to cover every conceivable situation you can face when using a chainsaw. Always exercise care and use your common sense. Avoid all situations which you consider to be beyond your capability. If you still feel uncertain about operating procedures after reading these instructions, you should consult an expert before continuing. Do not hesitate to contact us if you have any questions about the use of the chainsaw. We will willingly be of service and provide you with advice as well as help you to use your chainsaw both efficiently and safely.





# GENERAL SAFETY PRECAUTIONS

## Personal protective equipment



**WARNING!** Most chainsaw accidents happen when the chain touches the operator. You must use approved personal protective equipment whenever you use the chainsaw. Personal protective equipment cannot eliminate the risk of injury but it will reduce the degree of injury if an accident does happen.

- Approved protective helmet
- Hearing protection
- Protective goggles or a visor
- Gloves with chainsaw protection
- Trousers with chainsaw protection
- Boots with chainsaw protection, steel toe-cap and non-slip sole
- Always have a first aid kit nearby
- Fire extinguisher and shovel
- Clothes should be close-fitting without restricting your freedom of movement.



**IMPORTANT!** Sparks can come from the muffler, the bar and chain or other sources. Always have fire extinguishing tools available if you should need them. Help prevent forest fires.

## Chainsaw's safety equipment

In this section, the chainsaw's safety features and their function are explained. For inspection and maintenance see instructions under *Checking, maintaining and servicing chainsaw safety equipment*. See instructions under *What is what?*, to find where these parts are located on your chainsaw.

The life span of the chainsaw can be reduced, and the risk of accidents can increase if chainsaw maintenance is not carried out correctly and if service and/or repairs are not carried out professionally. If you need further information, please contact our Customer Support Department.



**WARNING!** Never use a chainsaw with defective safety components. Safety equipment must be inspected and maintained. See instructions under *Checking, maintaining and servicing chainsaw safety equipment*. If your chainsaw does not pass all the checks, please contact our Customer Support Department.

## Chain brake and front hand guard

Your chainsaw is equipped with a chain brake that is designed to stop the chain if you get a kickback. The chain brake reduces the risk of accidents, but only you can prevent them.



Take care when using your chainsaw and make sure the kickback zone of the bar never touches any object.

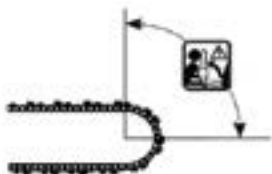

- The chain brake (A) can either be activated manually (by your left hand) or automatically by the inertia release mechanism.
- The brake is applied when the front hand guard (B) is pushed forwards.

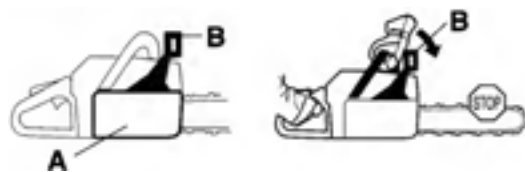

- This movement activates a spring-loaded mechanism that tightens the brake band (C) around the engine drive system (D) (clutch drum).

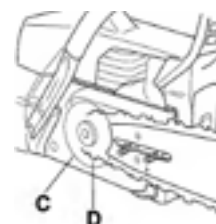

- The front hand guard is not designed solely to activate the chain brake. Another important feature is that it reduces the risk of the chain hitting your left hand if you lose grip of the front handle.



- The chain brake must be engaged when the chainsaw is started to prevent the saw chain from rotating.



# GENERAL SAFETY PRECAUTIONS

- Use the chain brake as a “parking brake” when starting and when moving over short distances, to reduce the risk of the moving chain accidentally hitting your leg, or anyone or anything close by.



- To release the chain brake pull the front hand guard backwards, towards the front handle.



- Kickback can be very sudden and violent. Most kickbacks are minor and do not always activate the chain brake. If this happens you should hold the chainsaw firmly and not let go.



- The way the chain brake is activated, either manually or automatically by the inertia release mechanism, depends on the force of the kickback and the position of the chainsaw in relation to the object that the kickback zone of the bar strikes.
- If you get a violent kickback while the kickback zone of the bar is farthest away from you, the chain brake is designed to be activated by the inertia in the kickback direction.



- If the kickback is less violent, or the kickback zone of the bar is closer to you, the chain brake is designed to be activated manually by the movement of your left hand.



- In the felling position, the left hand is in a position that makes manual activation of the chain brake impossible. With this type of grip, that is when the left hand is

placed so that it cannot affect the movement of the front hand guard, the chain brake can only be activated by the inertia action.



## ***Will my hand always activate the chain brake during a kickback?***

No. It takes a certain force to move the hand guard forward. If your hand only lightly touches the front guard or slips over it, the force may not be enough to trigger the chain brake. You should also maintain a firm grip on the chainsaw handles while working. If you do and experience a kickback, your hand may never leave the front handle and will not activate the chain brake, or the chain brake will only activate after the chainsaw has swung around a considerable distance. In such instances, the chain brake might not have enough time to stop the saw chain before it touches you.

There are also certain positions in which your hand cannot reach the front hand guard to activate the chain brake; for example, when the saw chain is held in the felling position.

## ***Will my inertia activated chain brake always activate during kickback in the event of a kickback?***

No. First, your brake must be in working order. Testing the brake is simple. We recommend you do before you begin each work session. Second, the kickback must be strong enough to activate the chain brake. If the chain brake is too sensitive it would activate all the time which would be a nuisance.

## ***Will my chain brake always protect me from injury in the event of a kickback?***

No. First, the chain brake must be in working order to provide the intended protection. Second, it must be activated during the kickback as described above to stop the saw chain. Third, the chain brake may be activated, but if the bar is too close to you, the brake might not have enough time to slow down and stop the chain before the chainsaw hits you.

**Only you and proper working technique can eliminate kickback and its danger.**

## **Throttle lock**

The throttle lock is designed to prevent accidental operation of the throttle control. When you press the lock (A) (i.e. when you grasp the handle) it releases the throttle control (B).

When you release the handle, the throttle control and the throttle lock both move back to their original positions. This arrangement means that the throttle control is automatically locked at the idle setting.

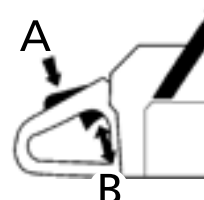

# GENERAL SAFETY PRECAUTIONS

## Chain catcher

The chain catcher is designed to catch the chain if it snaps or jumps off. This should not happen if the chain is properly tensioned (see instructions under *Assembly*) and if the bar and chain are properly serviced and maintained (see instructions under *General working instructions*).



## Right hand guard

Apart from protecting your hand if the chain jumps or snaps, the right-hand guard stops branches and twigs from interfering with your grip on the rear handle.



## Vibration damping system

Your chainsaw is equipped with a vibration damping system that is designed to reduce vibration and make operation easier.



The chainsaw's vibration damping system reduces the transfer of vibration between the engine unit/cutting equipment and the chainsaw's handle unit.

The body of the chainsaw, including the cutting equipment, is insulated from the handles by vibration damping units.



Cutting hardwoods (most broadleaf trees) creates more vibration than cutting softwoods (most conifers). Cutting with cutting equipment that is blunt or faulty (wrong type or badly sharpened) will increase the vibration level.



**WARNING!** Overexposure to vibration can lead to circulatory damage or nerve damage in people who have impaired circulation.

Contact your doctor if you experience symptoms of overexposure to vibration. Such symptoms include numbness, loss of feeling, tingling, pricking, pain, loss of strength, changes in skin colour or condition. These symptoms normally appear in the fingers, hands or wrists. These symptoms may be increased in cold temperatures.

## Stop switch

Use the stop switch to switch off the engine.

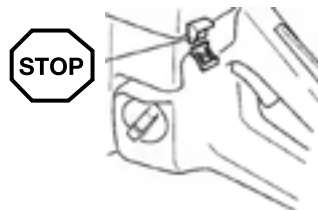

## Muffler

The muffler is designed to keep noise levels to a minimum and to direct exhaust fumes away from the user.



**WARNING!** The exhaust fumes from the engine are hot and may contain sparks, which can start a fire. Never start the chainsaw indoors or near combustible material!

In areas with a hot, dry climate there is a high risk of fires. These areas are sometimes subject to government rules requiring among other things the muffler must be equipped with an approved type of spark arrestor mesh.



**CAUTION!** The muffler gets very hot during and after use. This also applies during idling. Be aware of the fire hazard, especially when working near flammable substances and/or vapours.



**WARNING!** Never use a chainsaw without a muffler, or with a damaged muffler. A damaged muffler may substantially increase the noise level and the fire hazard. Keep fire fighting equipment handy.

## Cutting equipment

This section describes how to choose and maintain your cutting equipment in order to:

- Reduce the risk of kickback.
- Reduce the risk of the saw chain breaking or jumping off the bar.
- Obtain optimal cutting performance.
- Extend the life of cutting equipment.
- Avoid increasing vibration levels.

## General rules

- **Only use cutting equipment recommended by us!** See instructions under *Specifications*.



# GENERAL SAFETY PRECAUTIONS

- Keep the chain's cutting teeth properly sharpened! Follow our instructions and use the recommended file gauge. A damaged or badly sharpened chain increases the risk of accidents.



- Maintain the correct depth gauge setting! Follow our instructions and use the recommended depth gauge clearance. Too large a clearance increases the risk of kickback.



- Keep the chain properly tensioned! If the chain is slack it is more likely to jump off and lead to increased wear on the bar, chain and drive sprocket.



- Keep cutting equipment well lubricated and properly maintained! A poorly lubricated chain is more likely to break and lead to increased wear on the bar, chain and drive sprocket.



## Cutting equipment designed to reduce kickback



**WARNING!** Faulty cutting equipment or the wrong combination of bar and saw chain increases the risk of kickback! Only use the bar/saw chain combinations we recommend, and follow the filing instructions. See instructions under *Specifications*.

The only way to avoid kickback is to make sure that the kickback zone of the bar never touches anything.

By using cutting equipment with "built-in" kickback reduction and keeping the chain sharp and well-maintained you can reduce the effects of kickback.

### Bar

The smaller the tip radius the lower the chance of kickback.

### Chain

A chain is made up of a number of links, which are available in standard and low-kickback versions

**IMPORTANT!** No saw chain design eliminates the danger of kickback

### Some terms that describe the bar and chain

To maintain the safety features of the cutting equipment, you should replace a worn or damaged bar or chain with a bar and chain combinations recommended by us.

See instructions under *Specifications* for a list of replacement bar and chain combinations we recommend.

### Bar

- Length (inches/cm)
- Number of teeth on bar tip sprocket (T).

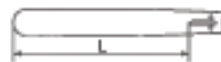

- Chain pitch (inches). The spacing between the drive links of the chain must match the spacing of the teeth on the bar tip sprocket and drive sprocket.



- Number of drive links. The number of drive links is determined by the length of the bar, the chain pitch and the number of teeth on the bar tip sprocket.



- Bar groove width (inches/mm). The groove in the bar must match the width of the chain drive links.



- Chain oil hole and hole for chain tensioner. The bar must be matched to the chainsaw design.



### Chain

- Chain pitch (inches)

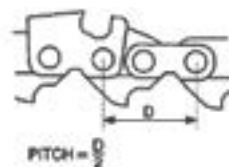

- Drive link width (mm/inches)



- Number of drive links.



# GENERAL SAFETY PRECAUTIONS

## Sharpening your chain and adjusting depth gauge setting

### General information on sharpening cutting teeth

- Never use a blunt chain. When the chain is blunt you have to exert more pressure to force the bar through the wood and the chips will be very small. If the chain is very blunt it will produce wood powder and no chips or shavings.
- A sharp chain eats its way through the wood and produces long, thick chips or shavings.



- The cutting part of the chain is called the cutter and consists of a cutting tooth (A) and the depth gauge (B). The cutters cutting depth is determined by the difference in height between the two (depth gauge setting).



When you sharpen a cutting tooth there are four important factors to remember.

#### 1. Filing angle



#### 2. Cutting angle



#### 3. File position



#### 4. Round file diameter



It is very difficult to sharpen a chain correctly without the right equipment. We recommend that you use our file gauge. This will help you obtain the maximum kickback reduction and cutting performance from your chain.



See instructions under *Specifications* for information about sharpening your chain.



**WARNING!** Departure from the sharpening instructions considerably increases the risk of kickback.

### Sharpening cutting teeth

To sharpen cutting teeth, you will need a round file and a file gauge. See instructions under *Specifications* for information on the size of the file and gauge that are recommended for the chain fitted to your chainsaw.



- Check that the chain is correctly tensioned. A slack chain will move sideways, making it more difficult to sharpen correctly.
- Always file cutting teeth from the inside face. Reduce the pressure on the return stroke. File all the teeth on one side first, then turn the chainsaw and file the teeth on the other side.



- File all the teeth to the same length. When the length of the cutting teeth is reduced to 4 mm (0.16") the chain is worn out and should be replaced.



### General advice on adjusting depth gauge setting

- When you sharpen the cutting tooth (A), the depth gauge setting (C) will decrease. To maintain optimal cutting performance the depth gauge (B) has to be filed down to achieve the recommended depth gauge setting.



See instructions under *Specifications* to find the correct depth gauge setting for your particular chain.



**WARNING!** The risk of kickback is increased if the depth gauge setting is too large!

### Adjustment of depth gauge setting

- The cutting teeth should be newly sharpened before adjusting the depth gauge setting. We recommend that you adjust the depth gauge setting every third time you sharpen the cutting teeth.

**NOTE:** This recommendation assumes that the length of the cutting teeth is not reduced excessively.

- You will need a flat file and a depth gauge tool. We recommend that you use our depth gauge tool to

# GENERAL SAFETY PRECAUTIONS

achieve the correct depth gauge setting and bevel for the depth gauge.

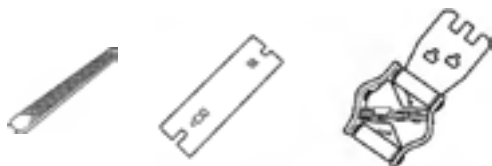

- Place the depth gauge tool over the chain. Detailed information regarding the use of the depth gauge tool will be found on the package for the depth gauge tool. Use the flat file to file off the tip of the depth gauge that protrudes through the depth gauge tool. The depth gauge setting is correct when you no longer feel resistance as you draw the file along the depth gauge tool.



## Tensioning the chain



**WARNING!** A slack chain may jump off the bar and cause serious or even fatal injury.

The more you use a chain the longer it becomes. It is therefore important to adjust the chain regularly to take up the slack.

Check the chain tension every time you refuel.

**NOTE:** A new chain has a running-in period during which you should check the tension more frequently.

- Loosen the bar nuts that hold the clutch cover/chain brake. Use the combination spanner. Then tighten the bar nuts by hand as tight as you can.



- Raise the tip of the bar and stretch the chain by tightening the chain tensioning screw using the combination spanner. Tighten the chain until it does not sag from the underside of the bar.

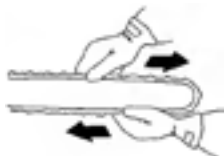

- Use the combination spanner to tighten the bar nuts while lifting the tip of the bar at the same time. Check that you can pull the chain round freely by hand and that it does not sag from the underside of the bar.



The position of the chain tensioning screw on our chainsaws varies from model to model. See instructions under *What is what?* to find out where it is on your model.



## Lubricating cutting equipment



**WARNING!** Poor lubrication of cutting equipment may cause the chain to snap, which could lead to serious, even fatal injuries.

### Chain oil

Chain oil must demonstrate good adhesion to the chain and maintain its flow characteristics regardless of whether it is warm summer or cold winter weather.

As a chainsaw manufacturer, we have developed an optimal chain oil that has a vegetable oil base.

**Never use waste oil!** Using waste oil can be dangerous to you and can damage your chainsaw and the environment.

### Filling with chain oil

- All our chainsaws have an automatic chain lubrication system. On some models the oil flow is also adjustable.



- The saw chain oil tank and the fuel tank are designed so that the fuel runs out before the saw chain oil. However, this safety feature requires that you:
  - Use the right sort of chain oil (if the oil is too thin it will run out before the fuel);
  - Adjust the carburettor as recommended (a lean mixture may mean that the fuel lasts longer than the oil); and
  - Use the recommended cutting equipment (a bar that is too long will use more chain oil).

### Checking chain lubrication

- Check the chain lubrication each time you refuel. Aim the tip of the bar at a light coloured surface about 20cm (8 inches) away. After 1 minute running at 3/4 throttle you should see a distinct line of oil on the light surface.



# GENERAL SAFETY PRECAUTIONS

If the chain lubrication is not working:

- Check that the oil channel in the bar is not obstructed. Clean if necessary.



- Check that the groove in the edge of the bar is clean. Clean if necessary.



- Check that the bar tip sprocket turns freely and that the lubricating hole in the tip sprocket is not blocked. Clean and lubricate if necessary.



If the chain lubrication system is still not working after carrying out the above checks and associated measures you should contact our Customer Support Department.

## Chain drive sprocket

The clutch drum is fitted with the following drive sprocket: Spur sprocket (the chain sprocket is welded on the drum)



Regularly check the degree of wear on the drive sprocket. Replace if wear is excessive. Replace the drive sprocket whenever you replace the chain.

## Needle bearing lubrication

Both versions of sprockets have a needle bearing on the drive shaft, which has to be greased regularly (once a week).



## Checking wear on cutting equipment

Check the chain daily for:

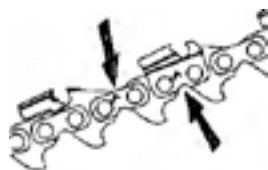

- Visible cracks in rivets and links.
- Whether the chain is stiff.
- Whether rivets and links are badly worn.

Replace the saw chain if it exhibits any of the points above.

We recommend you compare the existing chain with a new chain to decide how badly the existing chain is worn.

When the length of the cutting teeth has worn down to only 4mm (0.16 inches) the chain must be replaced.

## Bar

Check regularly:

- Whether there are burrs on the edges of the bar. Remove these with a file if necessary.



- Whether the groove in the bar has become badly worn. Replace the bar if necessary.



- Whether the tip of the bar is uneven or badly worn. If a hollow forms on the underside of the bar tip this is due to running with a slack chain.



- To prolong the life of the bar, you should turn it over daily.

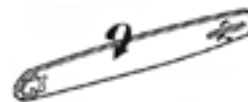

**WARNING!** Most chainsaw accidents happen when the chain touches the operator.

Wear personal protective equipment. See instructions under *Personal protective equipment*.

Do not tackle any job that you feel you are not adequately trained for. See instructions under *Personal protective equipment*.

Avoid situations where there is a risk of kickback. See instructions under *Chainsaw's safety equipment*.

Use the recommended protective equipment and check its condition. See instructions under *General working instructions*.

Check that all the chainsaw safety features are working. See Instructions under *General working instructions and General safety precautions*.

# ASSEMBLY

## Fitting the bar and chain



**WARNING!** Always wear gloves, when working with the chain, in order to protect your hands from injury.

Check that the chain brake is in the disengaged position by moving the front hand guard towards the front handle.



Remove the bar nuts and remove the clutch cover (chain brake). Take off the transportation ring (A).

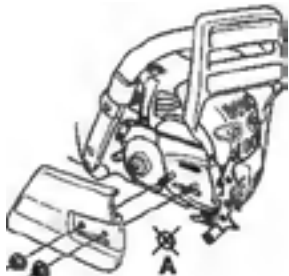

Fit the bar over the bar bolts. Place the bar in its rearmost position. Place the chain over the drive sprocket and locate it in the groove on the bar. Begin on the top edge of the bar.



Make sure that the edges of the cutting links are facing forward on the top edge of the bar.

Fit the clutch cover and locate the chain adjuster pin in the hole in the bar. Check that the drive links of the chain fit correctly over the drive sprocket and that the chain is correctly located in the groove in the bar. Tighten the bar nuts finger tight.



Tension the chain by turning the chain tensioning screw clockwise using the combination spanner.

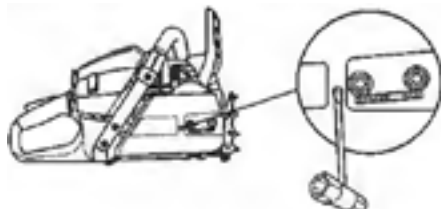

The chain is correctly tensioned when it does not sag from the underside of the bar, but can still be turned easily by hand. Hold up the bar tip and tighten the bar nuts with the combination spanner.

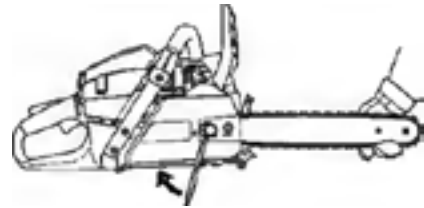

When fitting a new chain, the chain tension has to be checked frequently until the chain is run-in. Check the chain tension regularly. A correctly tensioned chain ensures good cutting performance and longer chain life.

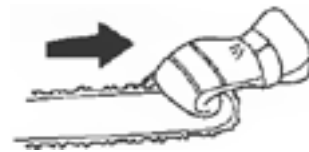

**NOTE:** If the clutch cover is difficult to remove, replace bar nuts, engage brake and rerelease (an audible click will be heard if released properly).



# FUEL HANDLING

## Fuel

**NOTE:** The chainsaw is equipped with a two-stroke engine and must always be run using a mixture of fuel and two-stroke oil. It is important to accurately measure the amount of oil to be mixed to ensure that the correct mixture is obtained. When mixing small amounts of fuel, even small inaccuracies can drastically affect the ratio of the mixture.



**WARNING!** Always ensure there is adequate ventilation when handling fuel.

- **This engine is certified to operate on unleaded fuel 95+ RON (research octane number) avoid ethanol.**
- Use good quality unleaded gasoline. Engines equipped with catalytic converters must be run on unleaded fuel mixtures.
- The lowest recommended octane grade is RON 95. If you run the engine on a lower octane grade than RON 95 so called knocking can occur. This gives rise to a high engine temperature and increased bearing load, which can result in serious engine damage.
- When working with continuous high revs (FB grade) a higher octane is recommended.

### Environment fuel

We recommend the use of alkylate fuel or environment fuel for four-stroke engines blended with two-stroke oil as set out below. Note that carburettor adjustment may be necessary when changing the type of fuel (see instructions under *Carburettor*).

### Running-in

Avoid running at a too high speed for extended periods during the first 10 hours of operation.

### Two-stroke oil

- For best results and performance use two-stroke oil, which is specially formulated for our two-stroke engines.
- Never use two-stroke oil intended for water-cooled outboard engines, sometimes referred to as outboard oil.
- Never use oil intended for four-stroke engines.

### Mixing ratio

For all engines: 1:25 (4%)

Petrol (litre)	Two-stroke oil (litre)
	4% (1:25)
5 L	0.20 L
10 L	0.40 L
15 L	0.60 L
20 L	0.80 L

## Mixing



- Always mix the fuel and oil in a clean container intended for fuel.
- Always start by filling half the amount of the fuel to be used. Then add the entire amount of oil. Mix (shake) the fuel mixture. Add the remaining amount of gasoline.
- Mix (shake) the fuel mixture thoroughly before filling the chainsaw's fuel tank.
- Do not mix more than one month's supply of fuel at a time.
- If the chainsaw will not be used for an extended period of time, the fuel tank should be emptied and cleaned.

## Chain oil

- We recommend the use of special oil (chain oil) with good adhesion characteristics.
- Never use waste oil. This results in damage to the oil pump, the bar and the chain.
- It is important to use oil of the right grade (suitable viscosity range) to suit the air temperature.

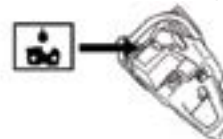

- In temperatures below 0°C, some oils become too viscous. This can overload the oil pump and result in damage to the oil pump components.
- Contact your service agent when choosing chain oil.

# FUEL HANDLING

## Fuelling



**WARNING!** Taking the following precautions will lessen the risk of fire:

Do not smoke and do not place any hot objects in the vicinity of fuel.

Always stop the engine and let it cool for a few minutes before refuelling.

When refuelling, open the fuel cap slowly so that any excess pressure is released gently.

Tighten the fuel cap carefully after refuelling.

Always move the chainsaw away from the refuelling area before starting.

Clean the area around the fuel cap. Clean the fuel and chain oil tanks regularly. The fuel filter must be replaced at least once a year. Contamination in the tanks causes malfunction. Make sure the fuel is well mixed by shaking the container before refuelling. The capacities of the chain oil tank and fuel tank are carefully matched. You should therefore always fill the chain oil tank and fuel tank at the same time.



**WARNING!** Fuel and fuel vapour are highly flammable. Take care when handling fuel and chain oil. Be aware of the risks of fire, explosion and those associated with inhalation.

## Fuel safety

- Never refuel the chainsaw while the engine is running.
- Move the chainsaw at least 3m from the refuelling point before starting it.

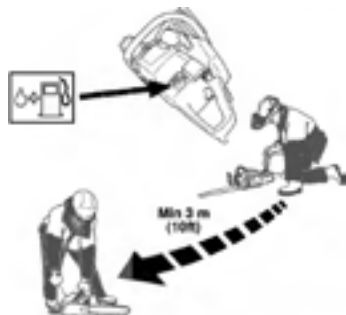

- Make sure there is plenty of ventilation when refuelling or mixing fuel (fuel and 2-stroke oil).
- Never start the chainsaw:
  1. If you have spilt fuel or chain oil on the chainsaw. Wipe off the spillage and allow remaining fuel to evaporate.
  2. If you have spilt fuel on yourself or your clothes. Change your clothes and wash any part of your body that has come in contact with fuel. Use soap and water.
  3. If the chainsaw is leaking fuel. Check regularly for leaks from the fuel cap and fuel lines



**WARNING!** Never use a chainsaw with visible damage to the spark plug guard and ignition cable. A risk of sparking arises, which can cause a fire.

## Transport and storage

- Always store the chainsaw and fuel so that there is no risk of leakages or fumes coming into contact with sparks or naked flames from electrical equipment, electric motors, relays/switches, boilers and the like.
- Always store fuel in an approved container designed for that purpose.
- For longer periods of storage or for transport of the chainsaw, the fuel and chain oil tanks should be emptied. Ask where you can dispose of waste fuel and chain oil at your local gas station.
- Ensure the chainsaw is cleaned and that a complete service is carried out before long-term storage.
- The bar guard must always be fitted to the cutting attachment when the chainsaw is being transported or in storage, in order to prevent accidental contact with the sharp chain. Even a non-moving chain can cause serious cuts to yourself or persons you bump into with an exposed chain.

## Long-term storage

Empty the fuel/oil tanks in a well-ventilated area. Store the fuel in approved containers in a safe place. Fit the bar guard. Clean the chainsaw. See instructions under *Maintenance schedule*.

# STARTING AND STOPPING



**WARNING!** Note the following before starting:

The chain brake must be engaged when the chainsaw is started to reduce the chance of contact with the moving chain.

Never start a chainsaw unless the bar, chain and all covers are fitted correctly. Otherwise, the clutch can come loose and cause personal injuries.

Place the chainsaw on firm ground. Make sure you have a secure footing and that the chain cannot touch anything.

Keep people and animals well away from working areas.



**WARNING!** Do not start the engine while holding the chainsaw with one hand. The saw chain may touch your body and cause serious injury.

Do not pull the starter cord all the way out and do not let go of the starter handle when the cord is fully extended. This can damage the chainsaw.

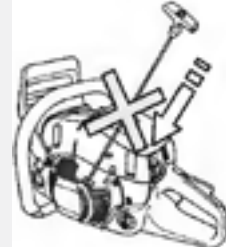

## Starting engine

1. Push the hand guard forward to engage the chain brake.



2. Pull the choke knob out. Move the ignition, switch to start position.

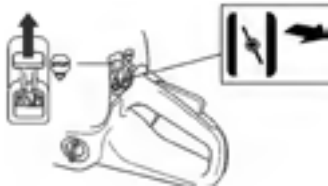

3. If the chainsaw is fitted with a decompression valve(A), please press the valve to reduce the pressure in the cylinder and make starting easier.

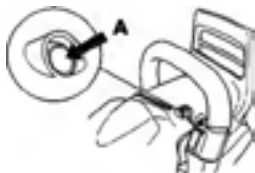

**CAUTION!** If the starter handle is pulled after the first firing sound is heard and the choke knob is in the start position, excess fuel will enter the engine causing the engine to fail to start.

4. Pull the starter handle several times until first firing sound is heard. Push the choke knob all the way in to open the choke, then pull the starter handle again.

**CAUTION!** Once the chainsaw has started the valve will automatically return to its closed position.

5. Immediately press and release the throttle when the engine starts. This will disengage the throttle latch. As the chain brake is still activated, the engine must return to latch in order to avoid unnecessary wear on the clutch assembly.

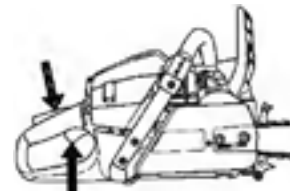

**NOTE!** Pull the front hand guard towards the front handle. The chain brake is now disengaged. Your chainsaw is ready for use.



**WARNING!** Long term inhalation of the engine's exhaust fumes, chain oil mist and dust from sawdust can represent a health risk.

- Never start a chainsaw unless the bar, chain and all covers are fitted correctly. See instructions under *Assembly*. Without a bar and chain attached to the chainsaw, the clutch can come loose and cause serious injury.



- Never start the chainsaw indoors. Exhaust fumes can be dangerous if inhaled.
- The chain brake should be activated when starting. See instructions under *Start and Stop*. Do not drop start the chainsaw. This method is very dangerous as you may lose control of the chainsaw.



# STARTING AND STOPPING

- Observe your surroundings and make sure that there is no risk of people or animals coming into contact with the cutting equipment.



- Always hold the chainsaw with both hands. The right hand should be on the rear handle, and the left hand on the front handle. All people, whether right or left handed, should use this grip. Use a firm grip with thumbs and fingers encircling the chainsaw handles.

## Stopping

The engine is stopped by pushing the stop switch to the stop position.

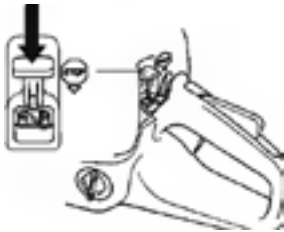

## Carburettor anti-freeze mechanism

Operating the chainsaw in temperatures of 0-5°C at times of high humidity may result in ice forming within the carburettor. This may cause the output power of the engine to be reduced or for the engine to fail to operate smoothly.

This product has accordingly been designed with a ventilation hatch at the back of the air cleaner cover to allow warm air to be supplied to the engine and to thereby prevent icing from occurring. (For some other models, a hot wind cover can adjust the hot air intake.)

Under normal circumstances, the product should be used in normal operating mode, which it is set at the time of shipment.

However, when the possibility exists that icing may occur, the unit should be set to operate in anti-freeze mode before use.

## How to switch between operating modes

### A. Switching by air filter cover

- Flip the engine switch to turn off the engine.
- Remove the air cleaner cover from the cylinder cover.
- Re-attach the screen right side left so as to the anti-icing plate is on the right. Reinstall the cover.

- Air cleaner cover
- Anti-icing plate
- Screw
- Normal operating mode
- Anti-freeze mode
- Screen

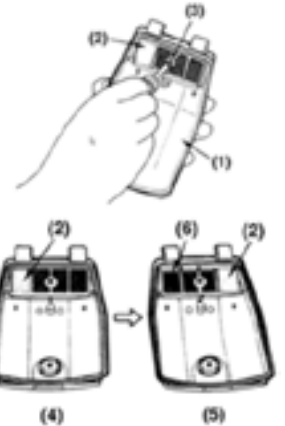

### B. Switching by hot wind cover

- Flip the engine switch to turn off the engine.
- Remove the air cleaner cover from the cylinder cover.
- Revolve the hot wind cover to the Anti-freeze mode.
- Re-install the cover.

- Air cleaner cover
- Hot wind cover
- Normal operating mode
- Anti-freeze mode

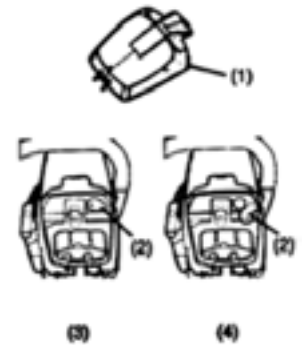

**WARNING!** Continuing to use the chainsaw in anti-freeze mode once temperatures have risen and returned to normal may result in the engine failing to start properly or in the engine failing to operate at its normal speed. For this reason you should always ensure the unit is set to normal operating mode if there is no danger of icing occurring.

# WORKING TECHNIQUES

## Before use

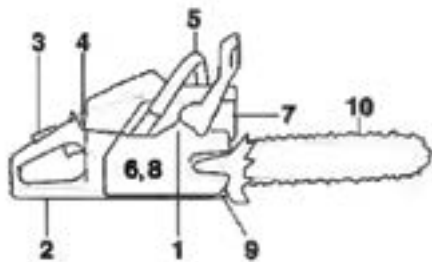

1. Check that the chain brake works correctly and is not damaged.
2. Check that the rear right hand guard is not damaged.
3. Check that the throttle lock works correctly and is not damaged.
4. Check that the stop switch works correctly and is not damaged.
5. Check that all handles are free from oil.
6. Check that the anti vibration system works and is not damaged.
7. Check that the muffler is securely attached and not damaged.
8. Check that all parts of the chainsaw are tightened correctly and that they are not damaged or missing.
9. Check that the chain catcher is in place and not damaged.
10. Check the chain tension.

## General working instructions

### IMPORTANT!

This section describes basic safety rules for using a chainsaw. This information is never a substitute for professional skills and experience. If you get into a situation where you feel unsafe; stop and seek expert advice. Contact our Customer Support Department or an experienced chainsaw user. Do not attempt any task that you are not sure you can handle!

Before using a chainsaw, you must understand the effects of kickback and how to avoid them. See instructions under *How to avoid kickback*.

Before using a chainsaw, you must understand the difference between cutting with the top and bottom edges of the bar. See instructions under *How to avoid kickback and Chainsaw's safety equipment*.

Wear personal protective equipment. See instructions under *Personal protective equipment*.

## Basic safety rules

1. Look around you:
  - To ensure that people, animals or other things cannot affect your control of the chainsaw.
  - To make sure that none of the above might come within reach of your saw or be injured by falling trees.



**CAUTION!** Follow the instructions above, but do not use a chainsaw in a situation where you cannot call for help in case of an accident.

2. Do not use the chainsaw in bad weather, such as dense fog, heavy rain, strong wind, intense cold, etc. Working in bad weather is tiring and often brings added risks, such as icy ground, unpredictable felling direction, etc.
3. Take great care when removing small branches and avoid cutting bushes (i.e. cutting many small branches at the same time). Small branches can be grabbed by the chain and thrown back at you, causing serious injury.



4. Make sure you can move and stand safely. Check the area around you for possible obstacles (roots, rocks, branches, ditches, etc.) in case you have to move suddenly. Take great care when working on sloping ground.



5. Take great care when cutting a tree that is under tension. A tree that is under tension may spring back to its normal position before or after being cut. If you position yourself incorrectly or make the cut in the wrong place, the tree may hit you or the chainsaw and cause you to lose control. Both situations can cause serious personal injury.



# WORKING TECHNIQUES

6. Before moving your chainsaw, switch off the engine and lock the chain using the chain brake. Carry the chainsaw with the bar and chain pointing backwards. Fit a guard to the bar before transporting the chainsaw or carrying it for any distance.



7. When you put the chainsaw on the ground, lock the saw chain using the chain brake and ensure you have a constant view of the chainsaw. Switch the engine off before leaving your chainsaw for any length of time.

## General rules

1. If you understand what kickback is and how it happens, you can reduce or eliminate the element of surprise. By being prepared you reduce the risk. Kickback is usually quite mild, but it can sometimes be very sudden and violent.
2. Always hold the chainsaw firmly with your right hand on the rear handle and your left hand on the front handle. Wrap your fingers and thumbs around the handles. You should use this grip whether you are right-handed or left-handed. This grip minimises the effect of kickback and lets you keep the chainsaw under control. Do not let go of the handles!



3. Most kickback accidents happen during limbing. Make sure you are standing firmly and that there is nothing in the way that might cause you trip or lose your balance.

Lack of concentration can lead to kickback if the kickback zone of the bar accidentally touches a branch, nearby tree or some other object.



Have control over the workpiece.

If the pieces you intend to cut are small and light, they can jam in the saw chain and be thrown towards you. Even if this does not appear to be dangerous, you may be caught off guard and lose control of the saw. Never saw stacked logs or branches without first separating them. Only saw one log or one piece at a time. Remove the cut pieces to keep your working area safe.

4. Never use the chainsaw above shoulder height and avoid cutting with the tip of the bar. Never use the chainsaw one-handed!



5. In order to keep control of your saw, always maintain a firm foothold. Never work on a ladder, in a tree or on any other insecure support.



6. Always use a fast cutting speed, i.e. full throttle.
7. Take great care when you cut with the top edge of the bar, i.e. when cutting from the underside of an object. This is known as cutting with a pushing chain. The chain tries to push the chainsaw back towards the user. If the saw chain is jamming, the saw may be pushed back at you.



8. Unless the user resists this pushing force there is a risk that the chainsaw will move so far backwards that only the kickback zone of the bar is in contact with the tree, which can lead to a kickback.

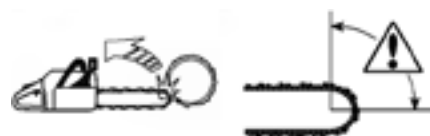

9. Cutting with the bottom edge of the bar, i.e. from the top of the object downwards, is known as cutting with a pulling chain. In this situation the chainsaw pulls itself towards the tree and the front edge of the chainsaw body rests naturally on the trunk when cutting. Cutting with a pulling chain gives the operator better control over the chainsaw and the position of the kickback zone.



10. Follow the instructions on sharpening and maintaining your bar and chain. When you replace the bar and chain use only combinations that are recommended by us. See instructions under *Cutting equipment and Specifications*.

# WORKING TECHNIQUES

## Basic cutting techniques



**WARNING!** Never use a chainsaw by holding it with one hand. A chainsaw is not safely controlled with one hand. Always have a secure, firm grip around the handles with both hands.

### General

- Always use full throttle when cutting!
- Reduce the speed to idle after every cut (running the engine for too long at full throttle without any load, i.e. without any resistance from the chain during cutting, can lead to serious engine damage).
- Cutting from above = Cutting with a pulling chain.
- Cutting from below = Cutting with pushing chain.

Cutting with a pushing chain increases the risk of kickback. See instructions under *How to avoid kickback*.

### Terms

Cutting = General term for cutting through wood.

Limbing = Cutting branches off a felled tree.

Splitting = When the object you are cutting breaks off before the cut is complete.

There are five important factors you should consider before making a cut:

1. Make sure the cutting equipment will not jam in the cut.



2. Make sure the object you are cutting will not split.



3. Make sure the chain will not strike the ground or any other object during or after cutting.



4. Is there a risk of kickback?

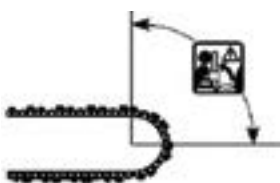

5. Do the conditions and surrounding terrain affect how safely you can stand and move about?

Two factors decide whether the chain will jam or the object that you are cutting will split: the first is how the object is supported before and after cutting, and the second is whether it is in tension.

In most cases you can avoid these problems by cutting in two stages; from the top and from the bottom. You need to support the object so that it will not trap the chain or split during cutting.



**WARNING!** If the chain jams in the cut: stop the engine! Never try to pull the chainsaw free. If you do, the chain may injure you when the chainsaw suddenly breaks free. Use a lever to open up the cut and free the chainsaw.

The following instructions describe how to handle the common situations you are likely to encounter when using a chainsaw.

## Limbing

When limbing thick branches you should use the same approach as for cutting.

Cut difficult branches piece by piece.



## Cutting



**WARNING!** Never attempt to cut logs while they are in a pile or when a couple of logs are lying together. Such procedures drastically increase the risk of kickback, which can result in a serious or fatal injury.

If you have a pile of logs, each log you attempt to cut should be removed from the pile, placed on a sawhorse or runners and cut individually.

Remove the cut pieces from the cutting area. By leaving them in the cutting area, you increase the risk for inadvertently getting a kickback, as well as increasing the risk of losing your balance while working.



# WORKING TECHNIQUES

**The log is lying on the ground.** There is little risk of the chain jamming or the object splitting. However there is a risk that the chain will touch the ground when you finish the cut.



Cut all the way through the log from above. Avoid letting the chain touch the ground as you finish the cut. Maintain full throttle but be prepared for what might happen.



If it is possible (can you turn the log?) stop cutting about 2/3 of the way through the log.

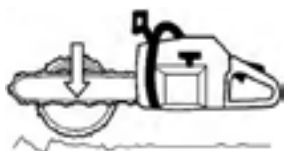

Turn the log and finish the cut from the opposite side.



**The log is supported at one end.** There is a high risk that it will split.



Start by cutting from below (about 1/3 of the way through).



Finish by cutting from above so that the two cuts meet.



**The log is supported at both ends.** There is a high risk that the chain will jam.



Start by cutting from above (about 1/3 of the way through).

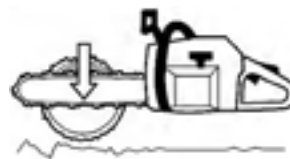

Finish by cutting from below so that the two cuts meet.

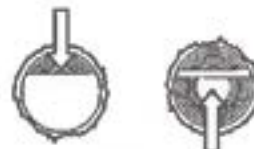

## Tree felling technique

**IMPORTANT!** It takes a lot of experience to fell a tree. Inexperienced users of chainsaws should not fell trees. Do not attempt any task beyond your experience level!

### Safe distance

The safe distance between a tree that is to be felled and anyone else working nearby is at least 2 1/2 tree lengths. Make sure that no-one else is in this "risk zone" before or during felling.

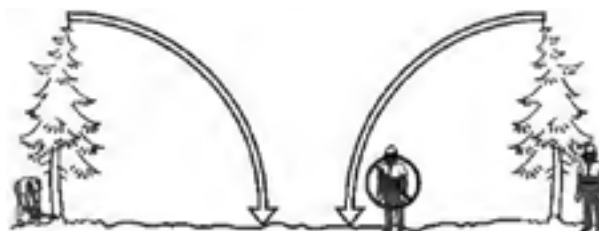

### Felling direction

The aim is to fell the tree in a position where you can limb and crosscut the log as easily as possible. You want it to fall in a location where you can stand and move about safely.

Once you have decided which way you want the tree to fall you must judge which way the tree would fall naturally.

Several factors affect this:

- Lean of the tree
- Bend
- Wind direction
- Arrangement of branches
- Weight of snow
- Obstacles within the reach of the tree: for example, other trees, power lines, roads and buildings.
- Look for signs of damage and rot in the trunk, this makes it more probable that the tree will break and start to fall before you expect it to.

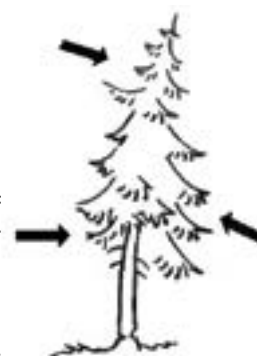

You may find you are forced to let the tree fall in its natural direction because it is impossible or dangerous to try and make it fall in the direction you first intended.



# WORKING TECHNIQUES

Another very important factor, which does not affect the felling direction but does affect your safety, is to make sure the tree has no damaged or dead branches that might break off and hit you during felling.

The main aim is to avoid letting the tree fall onto another tree. It is very dangerous to remove a trapped tree and there is a high accident risk. See instructions under *Freeing a tree that has fallen badly*.



**IMPORTANT!** During critical felling operations, hearing protectors should be lifted immediately once sawing is completed so that sounds and warning signals can be heard.

## Clearing the trunk and preparing your retreat



De-limb the trunk up to shoulder height. It is safer to work from the top down and to have the tree between you and the saw.

Remove any undergrowth from the base of the tree and check the area for obstacles (stones, branches, holes, etc.) so that you have a clear path of retreat when the tree starts to fall. Your path of retreat should be roughly 135 degrees away from the intended felling direction.

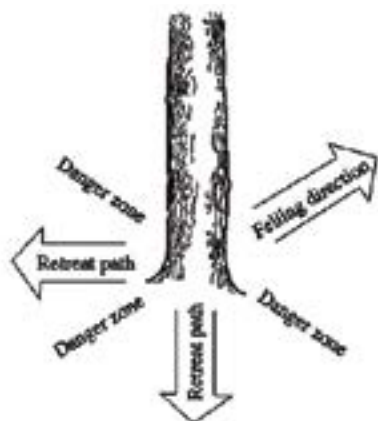

## Felling



**WARNING!** Unless you have specialised training, we advise you not to fell trees with a diameter larger than the bar length of your saw!

Felling is done using three cuts. First you make the directional cuts, which consist of the top cut and the bottom cut, then you finish with the felling cut. By placing these cuts correctly you can control the felling direction very accurately.

### Directional cuts

To make the directional cuts you begin with the top cut. Stand to the right of the tree and cut on the pull stroke.



Next make the bottom cut so that it finishes exactly at the end of the top cut.



The directional cuts should run 1/4 of the diameter through the trunk and the angle between the top cut and bottom cut should be 45°.



The line where the two cuts meet is called the directional cut line. This line should be perfectly horizontal and at right angles (90°) to the chosen felling direction.

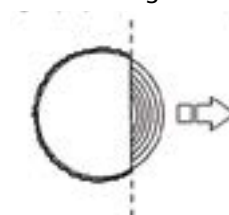

### Felling cut

The felling cut is made from the opposite side of the tree and it must be perfectly horizontal. Stand on the left side of the tree and cut on the pull stroke.

Make the felling cut about 3-5cm (1.5-2 inches) above the bottom directional cut.

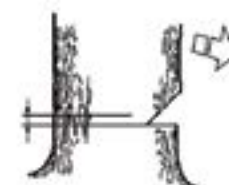

# WORKING TECHNIQUES

Set the spike bumper (if one is fitted) just behind the felling hinge. Use full throttle and bring the bar and chain slowly into the tree. Make sure the tree does not start to move in the opposite direction of your intended felling direction. Drive a wedge or breaking bar into the cut as soon as it is deep enough.

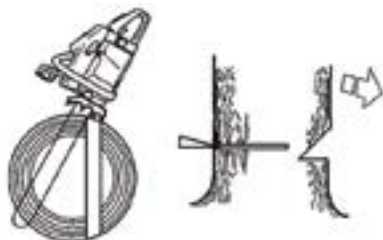

Finish the felling cut parallel with the directional cut line so that the distance between them is at least 1/10 of the trunk diameter. The uncut section of the trunk is called the felling hinge.

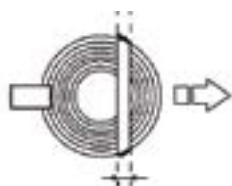

The felling hinge controls the direction that the tree falls in.



All control over the felling direction is lost if the felling hinge is too narrow or non-existent, or if the directional cuts and felling cut are badly placed.



When the felling cut and directional cut are complete, the tree should start to fall by itself or with the aid of a felling wedge or breaking bar.



We recommend that you use a bar that is longer than the diameter of the tree, so that you can make the felling cut and directional cuts with single cutting strokes. See instructions under *Specifications* to find out which lengths of bar are recommended for your saw.

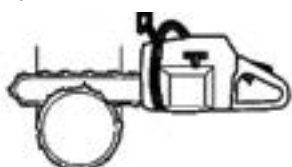

There are methods for felling trees with a diameter larger than the bar length. However, these methods involve a much greater risk that the kickback zone of the bar will come into contact with the tree.

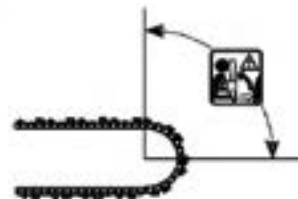

## Freeing a tree that has fallen badly

### Freeing a "trapped tree"

It is very dangerous to remove a trapped tree and there is a high accident risk.

Never try to fell the tree that is trapped



Never work in the risk zone of the hanging trapped tree.



The safest method is to use a winch.

- Tractor-mounted



- Portable



## Cutting trees and branches that are in tension

Preparations: Work out which side is in tension and where the point of maximum tension is (i.e. where it would break if it was bent even more).



# WORKING TECHNIQUES

Decide which is the safest way to release the tension and whether you are able to do it safely. In complicated situations the only safe method is to put aside your chainsaw and use a winch.

## General advice:

Position yourself so that you will be clear of the tree or branch when the tension is released.



Make one or more cuts at or near the point of maximum tension. Make as many cuts of sufficient depth as necessary to reduce the tension and make the tree or branch break at the point of maximum tension.



## Never cut straight through a tree or branch that is in tension!

If you must cut across a tree/limb, make two to three cuts, one inch apart, one to two inches deep.



Continue to cut deeper until tree/limb bends and tension is released.



Cut tree/limb from outside the bend, after tension has been released.

## How to avoid kickback



**WARNING!** Kickback can happen very suddenly and violently; kicking the chainsaw, bar and chain back at the user. If this happens when the chain is moving, it can cause very serious, even fatal, injuries. It is vital you understand what causes kickback and that you can avoid it by taking care and using the right working technique.

## What is kickback?

The word kickback is used to describe the sudden reaction that causes the chainsaw and bar to jump off an object when the upper quadrant of the tip of the bar, known as the kickback zone, touches an object.



Kickback always occurs in the cutting plane of the bar. Normally the chainsaw and bar are thrown backwards and upwards towards the user. However, the chainsaw may move in a different direction depending on the way it was being used when the kickback zone of the bar touched the object.



Kickback only occurs if the kickback zone of the bar touches an object.



## Limbing



**WARNING!** The majority of kickback accidents occur during limbing. Do not use the kickback zone of the guide bar. Be extremely cautious and avoid contacting the log, other limbs or objects with the nose of the guide bar. Be extremely cautious of limbs under tension. They can spring back toward you and cause loss of control resulting in injury.

Make sure that you can stand and move about safely. Work on the left side of the trunk. Work as close as possible to the chainsaw for maximum control. If possible, let the weight of the chainsaw rest on the trunk.



Keep the trunk between you and the chainsaw as you move along the trunk.

## Cutting the trunk into logs

See instructions under *Basic cutting techniques*.

# MAINTENANCE

## General

The user must only carry out the maintenance and service work described in this manual. More extensive work must be carried out by an authorised service workshop.

## Function

- The carburettor governs the engine's speed via the throttle control. Air and fuel are mixed in the carburettor. The air/ fuel mixture is adjustable. Correct adjustment is essential to get the best performance from the chainsaw.
- The setting of the carburettor means that the engine is adapted to local conditions, for example, the climate, altitude, fuel and the type of 2-stroke oil.
- The carburettor has three adjustment controls:  
L = Low speed jet  
H = High speed jet  
T = Idle adjustment screw

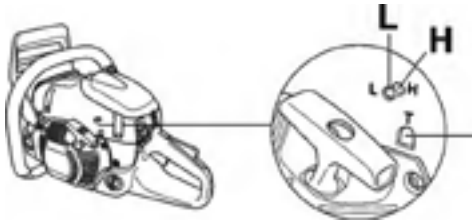

- The L and H-jets are used to adjust the supply of fuel to match the rate that air is admitted, which is controlled with the throttle. If they are turned clockwise the air/ fuel ratio becomes leaner (less fuel) and if they are turned anti clockwise the ratio becomes richer (more fuel). A lean mixture gives a higher engine speed and a rich mixture gives a lower engine speed.
- The T-screw regulates the throttle setting at idle speed. If the T-screw is turned clockwise this gives a higher idle speed; turning it anti-clockwise gives a lower idle speed.

## Basic settings and running in

The basic carburettor settings are adjusted during testing at the factory. Avoid running at a too high speed for extended periods during the first 10 hours. Rec. idle speed: 2700 rpm

**CAUTION** If the chain rotates while idling the T-screw must be turned anti-clockwise until the chain stops

## Fine adjustment

When the chainsaw has been "run-in" the carburettor should be finely adjusted. A qualified person should carry out the fine adjustment. First adjust the L-jet, then the idling screw T and then the H-jet.

## Conditions

- Before any adjustments are made, the air filter should be clean and the cylinder cover fitted. Adjusting the carburettor while a dirty air filter is in use will result in a leaner mixture next time the filter is cleaned. This can give rise to serious engine damage.
- **Do not attempt to adjust the L and H jets beyond either stop as this could cause damage.**
- Now start the chainsaw according to the starting instructions and let it warm up for 10 minutes.

- Place the chainsaw on a flat surface so that the bar points away from you and so that the bar and chain do not come into contact with the surface or other objects.

## Low speed jet L

Turn the low speed jet L clockwise until it stops. If the engine accelerates poorly or idles unevenly, turn the low speed jet L anti-clockwise until good acceleration and idling is achieved.

## Fine adjustment of the idling speed T

Adjust the idle speed with the T-screw. If it is necessary to re-adjust, turn the T-screw clockwise while the engine is running, until the chain starts to rotate. Then turn anti-clockwise until the chain stops. A correctly adjusted idle speed setting occurs when the engine runs smoothly in every position. It should also be good margin to the rpm when the chain starts to rotate.



**WARNING!** Contact our Customer Support Department, if the idle speed setting cannot be adjusted so that the chain stops. Do not use the chainsaw until it has been properly adjusted or repaired.

## High speed jet H

**At the factory the engine is adjusted at sea level. When working at a high altitude or in different weather conditions, temperatures and atmospheric humidity, it may be necessary to make minor adjustments to the high speed jet.**

**CAUTION** If the high speed jet is screwed in too far, it may damage the piston/cylinder.

When test run at the factory, the high speed jet is set so that the engine satisfies the applicable legal requirements while at the same time as achieving maximum performance. The carburettor's high speed jet is then locked using a limiter cap in the fully screwed out position. The limiter cap limits the potential to adjust the high speed jet to at most half a turn.

## NOTE

Be sure to adjust the carburettor with the bar chain attached.

1. Stop engine and screw in both H and L needles until they stop. Never force them. Then set them back the initial number of turns as shown below.  
H needle:  $1\frac{1}{4} \pm \frac{1}{4}$   
L needle:  $1\frac{1}{2} \pm \frac{1}{4}$
2. Start the engine and allow it to warm up at half-throttle.
3. Turn L needle slowly clockwise to find a position where idling speed is maximum. Then turn the needle back a quarter (1/4) turn anti-clockwise.
4. Turn idle adjusting screw(T) anti-clockwise so that the saw chain does not turn. If idling speed is too slow. Turn the screw clockwise.
5. Make a test cut and adjust the H needle for best cutting power, not for maximum speed.
  - a. L needle
  - b. H needle
  - c. Idle adjusting screw

# MAINTENANCE

## Correctly adjusted carburettor

When the carburettor is correctly adjusted the chainsaw accelerates without hesitation and the chainsaw 4-cycles a little at max. speed. It is also important that the chain does not rotate at idle. If the L-jet is set too lean it may cause starting difficulties and poor acceleration. If the H-jet is set too lean the chainsaw will have less power, poor acceleration and could suffer damage to the engine.

## Checking, maintaining and servicing chainsaw safety equipment

**NOTE:** All servicing and repair work on the chainsaw requires specialised training. This is especially true of the chainsaw's safety equipment. If your chainsaw fails any of the checks described below, we recommend you to contact our Customer Support Department.

## Chain brake and front hand guard

### Checking brake band wear

Brush off any wood dust, resin and dirt from the chain brake and clutch drum. Dirt and wear can impair operation of the brake.



Regularly check that the brake band is at least 0.6mm (0.024 inches) thick at its thinnest point.

### Checking the front hand guard

Make sure the front hand guard is not damaged and that there are no visible defects such as cracks.



Move the front hand guard forwards and back to make sure it moves freely and that it is securely anchored to the clutch cover.



## Checking the inertia brake release

With the engine turned off, hold the chainsaw over a stump or other firm object. Let go of the front handle so that the bar drops towards the stump as the chainsaw rotates around the rear handle.



When the bar hits the stump the brake should be applied.



## Checking the brake trigger

Place the chainsaw on firm ground and start the engine. Make sure the chain does not touch the ground or any other object. See the instructions under *Start and stop*.



Grasp the chainsaw firmly, wrapping your fingers and thumbs around the handles.



Apply full throttle and activate the chain brake by tilting your left wrist forward onto the front hand guard. Do not let go of the front handle. **The chain should stop immediately.**

## Throttle lock

- Make sure the throttle control is locked at the idle setting when the throttle lock is released.



- Press the throttle lock and make sure it returns to its original position when you release it.



# MAINTENANCE

- Check that the throttle control and throttle lock move freely and that the return springs work properly.



- Start the chainsaw and apply full throttle. Release the throttle control and check that the chain stops and remains stationary. If the chain rotates when the throttle control is in the idle position you should check the carburettor idle adjustment.

## Chain catcher

Check that the chain catcher is not damaged and is firmly attached to the body of the chainsaw.

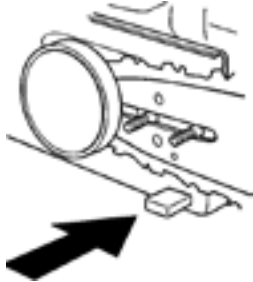

## Right hand guard

Check that the right hand guard is not damaged and that there are no visible defects, such as cracks.



## Vibration damping system

Regularly check the vibration damping units for cracks or deformation.



Make sure the vibration damping units are securely attached to the engine unit and handle unit.



## Stop switch

Start the engine and make sure the engine stops when you move the stop switch to the stop setting.

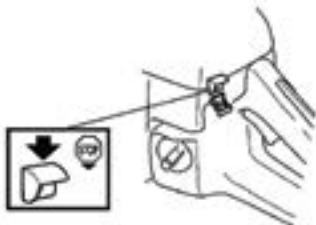

## Muffler

Never use a chainsaw that has a faulty muffler.



Regularly check that the muffler is securely attached to the chainsaw.

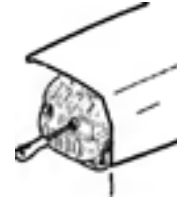

Some mufflers are equipped with a special spark arrestor mesh. If your chainsaw has this type of muffler, you should clean the mesh at least once a week. This is best done with a wire brush. Blocked mesh will cause the engine to overheat and may lead to serious damage.

**NOTE:** The mesh must be replaced if it is damaged. If the mesh is blocked, the chainsaw will overheat and this will cause damage to the cylinder and piston. Never use a chainsaw with a muffler that is in poor condition.

Never use a muffler if the spark arrestor mesh is missing or defective.

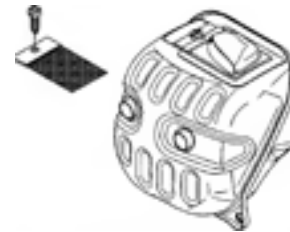

The muffler is designed to reduce noise level and direct exhaust gases away from the operator. Exhaust gases are hot and can contain sparks, which may cause fire if directed against dry and combustible material.

## Starter

### Changing a broken or worn starter cord

- Loosen the screws that hold the starter against the crankcase and remove the starter.

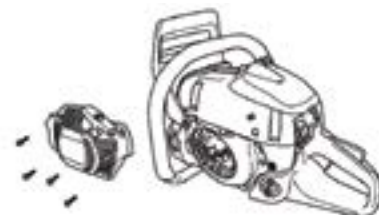

# MAINTENANCE

- Pull out the cord approx. 30cm (12 inches) and hook it into the notch in the rim of the pulley. Release the recoil spring by letting the pulley rotate slowly backwards.

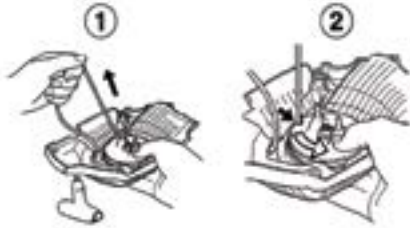

- Undo the screw in the centre of the pulley and remove the pulley. Insert and fasten a new starter cord to the pulley. Wind approx. 3 turns of the starter cord onto the pulley. Connect the pulley to the recoil spring so that the end of the spring engages in the pulley. Fit the screw in the centre of the pulley. Insert the starter cord through the hole in the starter housing and the starter handle. Make a secure knot in the end of the starter cord.



## Tensioning the recoil spring

- Hook the starter cord in the notch in the pulley and turn the starter pulley about 2 turns clockwise.

**NOTE:** Check that the pulley can be turned an additional 1/2 turn when the starter cord is pulled all the way out.



## Changing a broken recoil spring

- Lift off the pulley. See instructions under *Changing a broken or worn starter cord*.
- Remove the recoil spring from inside the pulley by tapping the pulley lightly with its inside face downwards against a work bench or similar. If the spring pops out during fitting, wind it up again, working from the outside in towards the centre.
- Lubricate the recoil spring with light oil. Fit the pulley and tension the recoil spring.

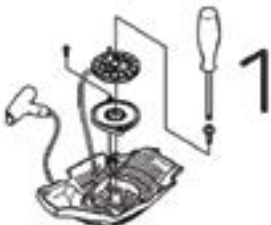

## Fitting the starter

- To fit the starter, first pull out the starter cord and place the starter in position against the crankcase. Then slowly release the starter cord so that the pulley engages with the pawls.
- Fit and tighten the screws that hold the starter.



## Air filter

The air filter must be regularly cleaned to remove dust and dirt in order to avoid:

- Carburettor malfunctions
- Starting problems
- Loss of engine power
- Unnecessary wear to engine parts
- Excessive fuel consumption.



- Remove the air filter after taking off the air filter cover. When re-fitting, make sure that the air filter seals tightly against the filter holder. Clean the filter by brushing or shaking it.



The filter can be cleaned more thoroughly by washing it in water and detergent.



An air filter that has been in use for a long time cannot be cleaned completely. The filter must therefore be replaced with a new one at regular intervals. **A damaged air filter must always be replaced.**

## Spark plug

The spark plug condition is influenced by:

- Incorrect carburettor adjustment.
- An incorrect fuel mixture (too much or incorrect type of oil).
- A dirty air filter.

These factors cause deposits on the spark plug electrodes, which may result in operating problems and starting difficulties.

# MAINTENANCE

If the chainsaw is low on power, difficult to start or runs poorly at idle speed, always check the spark plug first before taking any further action. If the spark plug is dirty, clean it and check that the electrode gap is 0.7mm (0.028 inches). The spark plug should be replaced after about a month of operation or earlier if necessary.



**NOTE:** Always use the recommended spark plug type! Use of the wrong spark plug can damage the piston/cylinder. Check that the spark plug is fitted with a suppressor.

## Lubricating the bar tip sprocket

Lubricate the bar tip sprocket each time you refuel. Use the special grease gun and a good quality bearing grease.



## Needle bearing lubrication

The clutch drum has a needle bearing on the output shaft. This needle bearing must be lubricated regularly (once a week). **CAUTION!** Use only high quality bearing grease or engine oil. See instructions under *Cutting equipment*.

## Adjustment of the oil pump

The oil pump is adjustable. Adjustments are made by turning the screw using a screwdriver or combination spanner. The chainsaw is supplied from the factory set to 1 turn open.

Turning the screw clockwise will reduce the oil flow and turning the screw anti-clockwise will increase the oil flow.



Recommended settings:

Bar 22" -24": 3 turns from the closed position.



**WARNING!** The engine must be stopped when making adjustments.

## Cooling system

To keep the working temperature as low as possible the chainsaw is equipped with a cooling system.

The cooling system consists of:

1. Air intake on the starter.
2. Air guide plate.
3. Fins on the flywheel.
4. Cooling fins on the cylinder.
5. Cylinder cover (directs cold air over the cylinder).

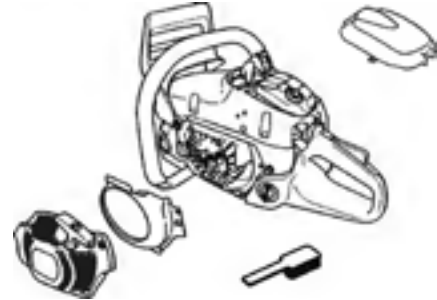

Clean the cooling system with a brush once a week, more often in demanding conditions. A dirty or blocked cooling system results in the chainsaw overheating, which causes damage to the piston and cylinder.

**NOTE:** The cooling system on a chainsaw with a catalytic converter must be cleaned daily. This is particularly important on chainsaws with catalytic converters as the higher exhaust temperature requires efficient cooling of the engine and the catalytic converter unit.

## "Air Injection" centrifugal cleaning

Centrifugal cleaning means the following:

- All air to the carburettor passes through the starter.
- Dirt and dust is pushed out by the cooling fan.

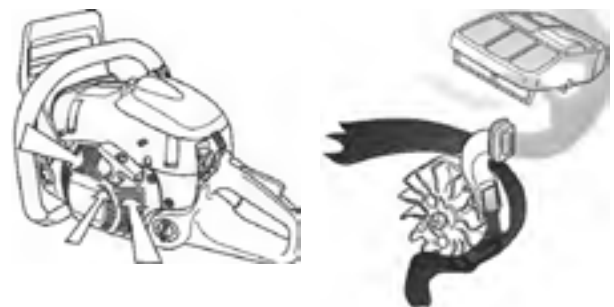

**IMPORTANT!** In order to maintain operation of the centrifugal cleaning system it must be regularly maintained. Clean the air intake to the starter, the fins on the flywheel, the space around the flywheel, inlet pipe and carburettor compartment.



# MAINTENANCE

## Maintenance schedule

The following is a list of the maintenance that must be performed on the chainsaw. Most of the items are described in the *Maintenance section*.

Daily maintenance	Weekly maintenance	Monthly maintenance
Clean the outside of the chainsaw.	On chainsaws without a catalytic converter, check the cooling system weekly.	Check the brake band on the chain brake for wear. Replace when less than 0.6mm (0.024 inches) remains at the most worn point.
Check that the components of the throttle control work safely. (Throttle lock and throttle control.)	Check the starter, starter cord and return spring.	Check the clutch centre, clutch drum and clutch spring for wear.
Clean the chain brake and check that it operates safely. Make sure that the chain catcher is undamaged, and replace it if necessary.	Check that the vibration damping elements are not damaged.	Clean the spark plug. Check that the electrode gap is 0.7mm (0.028 inches).
The bar should be turned daily for more even wear. Check the lubrication hole in the bar, to be sure it is not clogged. Clean the bar groove. If the bar has a sprocket tip, this should be lubricated.	Lubricate the clutch drum bearing.	Clean the outside of the carburettor.
Check that the bar and chain are getting sufficient oil.	File off any burrs from the edges of the bar.	Check fuel hose for cracks or other damage. Change if necessary.
Check the saw chain with regard to visible cracks in the rivets and links, whether the saw chain is stiff or whether the rivets and links are abnormally worn. Replace if necessary.	Clean or replace the spark arrestor mesh on the muffler.	Empty the fuel tank and clean the inside.
Sharpen the chain and check its tension and condition. Check the drive sprocket for excessive wear and replace if necessary.	Clean the carburettor compartment.	Empty the oil tank and clean the inside.
Clean the starter unit's air intake.	Clean the air filter. Replace if necessary.	Check all cables and connections.
Check that nuts and screws are tight.		
Check that the stop switch works correctly.		

# MAINTENANCE

KEY	MAINTENANCE ITEM	MAINTENANCE CYCLE					MAINTENANCE REQUEST
		EVERY TIME	20h	50h	100h	200h	
1	Fuel mixing ratio	25 : 1					25 : 1
2	Use up the remaining fuel in carburettor	•					Use up the remaining fuel when the chainsaw will not be used again for at least 48 hours later
3	Clean up the sawdust	•					The place where there is sawdust such as the cover, guide bar and feeding port
4	Check the tensioner parts	•					Tighten the loose bolt, screw and nut
5	Spark plug		•				Clean the electrodes and reset the gap to 0.6 - 0.7 mm
6					•		Clean or replace if necessary
7	Oil / Fuel filter			•			Clean
8						•	Clean or replace if necessary
9	Pipe of fuel					•	Clean or replace if necessary
10	Air filter		•				Clear the dust
11					•		Clean or replace if necessary
12	Piston, Piston ring				•	•	Clean if necessary
13	Cylinder					•	Clean or replace if necessary
14	Oil pump worn				•	•	Clean or replace if necessary
15	Clutch, Drum, Rim					•	Clean or replace if necessary
16	Oil / Fuel tank			•			Clear any impurity, dirt
17	Guide bar	•		•			Clean the groove of guide bar; Grease the nose sprocket
18						•	Clean or replace if necessary
19	Saw chain			•			Sharpen the cutter teeth of chain
20						•	Clean or replace if necessary
21	Starter			•			Clear sawdust and other dirty things
22	Chain brake	•					Check the chain brake before operating

# TROUBLESHOOTING

Trouble		Cause	Remedy
Engine	<ul style="list-style-type: none"> <li>• Starts hard</li> <li>• Does not start</li> </ul>		
Engine	Fuel at carburettor → No fuel at carburettor ↓ Fuel at cylinder → No fuel at cylinder ↓ Silencer wet with fuel	<ul style="list-style-type: none"> <li>• Fuel filter clogged</li> <li>• Fuel line clogged</li> <li>• Carburettor</li> </ul>	<ul style="list-style-type: none"> <li>• Clean or replace</li> <li>• Clean</li> <li>• Ask our Customer Support Department</li> </ul>
		<ul style="list-style-type: none"> <li>• Carburettor</li> </ul>	<ul style="list-style-type: none"> <li>• Ask our Customer Support Department</li> </ul>
		<ul style="list-style-type: none"> <li>• Fuel mixture is too rich</li> </ul>	<ul style="list-style-type: none"> <li>• Open choke</li> <li>• Clean/replace air filter</li> <li>• Adjust carburettor</li> <li>• Ask our Customer Support Department</li> </ul>
	Spark at end of plug wire → No spark at end of plug wire ↓ Spark at plug → No spark at plug	<ul style="list-style-type: none"> <li>• Ignition switch off</li> <li>• Electrical problem</li> </ul>	<ul style="list-style-type: none"> <li>• Turn switch on</li> <li>• Ask our Customer Support Department</li> </ul>
		<ul style="list-style-type: none"> <li>• Spark gap incorrect</li> <li>• Covered with carton</li> <li>• Fouled with fuel</li> <li>• Spark plug defective</li> </ul>	<ul style="list-style-type: none"> <li>• Adjust 0.6 to 0.7 mm</li> <li>• Clean or replace</li> <li>• Clean or replace</li> <li>• Replace plug</li> </ul>
Engine does not crank		<ul style="list-style-type: none"> <li>• Internal engine problem</li> </ul>	<ul style="list-style-type: none"> <li>• Ask our Customer Support Department</li> </ul>
Engine runs	Dies or accelerates poorly ↓	<ul style="list-style-type: none"> <li>• Air filter dirty</li> <li>• Fuel filter dirty</li> <li>• Fuel vent plugged</li> <li>• Spark plug</li> <li>• Carburettor</li> <li>• Cooling system plugged</li> <li>• Exhaust port/silencer plugged</li> </ul>	<ul style="list-style-type: none"> <li>• Clean or replace</li> <li>• Clean or replace</li> <li>• Clean</li> <li>• Clean and adjust/replace</li> <li>• Adjust</li> <li>• Clean</li> <li>• Clean</li> </ul>



**WARNING!** ALL CHAINSAW SERVICE, OTHER THAN ITEMS LISTED IN THE OWNER'S MANUAL SHOULD BE PERFORMED BY A COMPETENT SERVICE PROFESSIONAL

# SPECIFICATIONS

<b>Model name</b>		4100
<b>External dimensions: L x M x N</b>		390 x 240 x 275 mm
<b>Dry weight:</b>	Saw without guide bar and chain empty tanks	4.3kg
<b>Volume:</b>	Fuel tank	410 cm <sup>3</sup>
	Tank of chain lubrication oil	240 cm <sup>3</sup>
<b>Cutting length:</b>	usable cutting lengths of standard guide bar	16" (380) mm
<b>Saw Chain:</b>	Standard guide bar and chain	91P056X
	Specified pitch	3/8" (9.525 mm),
	Specified gauge (thickness of drive links)	0.050" (1.27 mm)
<b>Guide bar</b>		Oregon: 160SDEA041 16-56-50-3/8
<b>Sprocket:</b>	Specified number of teeth x pitch	6T x 9.525 Ntmm
<b>Chain oil</b>		SAE20# in summer and SAE10# in winter
<b>Petrol:</b>	2-cycle motor oil	25 : 1
<b>Type</b>		Air cooled 2-cycle single cylinder
<b>Carburettor</b>		Cylinder Diaphragm type
<b>Type of carburettor</b>		Walbro WT805
<b>Spark plug</b>		Champion RCJ6Y
<b>Magneto</b>		Fly wheel magneto, CDI system
<b>Engine displacement</b>		39.6 cm <sup>3</sup>
<b>Maximum shaft brake power: (ISO 7293)</b>		1.5 KW
<b>Max. chain speed</b>		21 mis
<b>Engine speed:</b>	Maximum speed with cutting attachment	12000 r/min
	Engine idling speed range	3300±400 r/min
	Minimum clutch engagement speed	4700 r/min
<b>F u e l c o n s u m p t i o n : (ISO 7293)</b>	Fuel consumption at maximum engine power	0.85 kg/h
	Specific fuel consumption at maximum engine power	566 glkw.h
<b>Chain brake: (ISO 6535)</b>	Mean braking time at racing speed	0.06 seconds
<b>Vibrations: (ISO 7505)</b>		9.5 m/s <sup>2</sup>
<b>Sow1d pressure level: (EN 27182) LpAav=</b>		102.8 db(A)
<b>Sow1d pressure level: (ISO/Dis 9207) LwAav=</b>		116 db(A)

SPECIFICATIONS ARE SUBJECT TO CHANGE WITHOUT NOTICE

# WARRANTY & SERVICE

---

## Warranties

---

Bigger Boz Toyz offer a 1-year parts warranty on all products used for domestic use from the date of purchase. For all commercial use, a 3-month parts warranty period applies, unless specified in the item listing. All conditions below are based upon the product being faulty or not performing as described. In the instance where a return is required, the purchaser is liable for any shipping cost. Warranties will only be determined by a Bigger Boz Toyz Technician upon inspection.

Warranties do not cover accidents, misuse, neglect, natural disaster or act of God or other external causes, or damage caused by operating the equipment in a manner that is not described in the instructions. Warranties do not cover Consumables such as Chains, Bars or pull starts.

Our goods come with guarantees that cannot be excluded under the Australian Consumer Law. You are entitled to a replacement or refund for a major failure and for compensation for any other reasonably foreseeable loss or damage. You are also entitled to have the goods repaired or replaced if the goods fail to be of acceptable quality and the failure does not amount to a major failure.

---

## Spare Parts

---

Spare parts are available. Please see our website ([www.bbta.com.au](http://www.bbta.com.au)) or contact us at [bbt@bbta.com.au](mailto:bbt@bbta.com.au) for more details.

# EXPLODED DIAGRAM & PARTS LIST

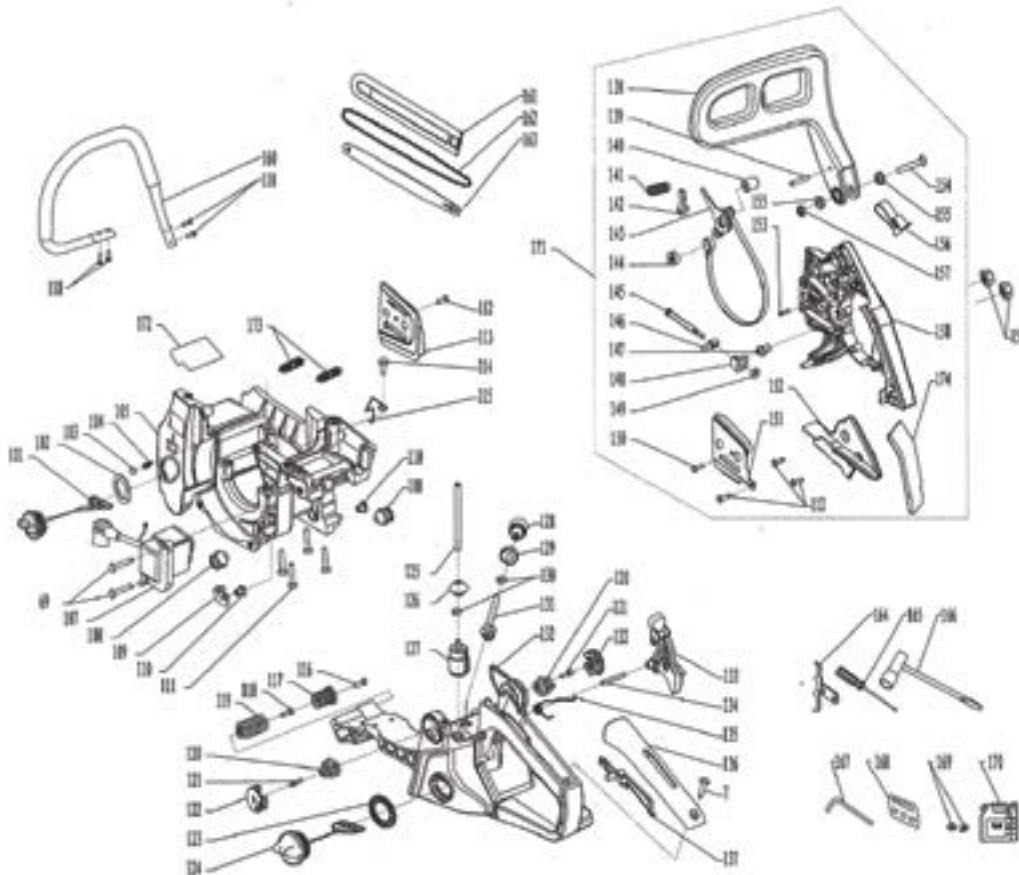
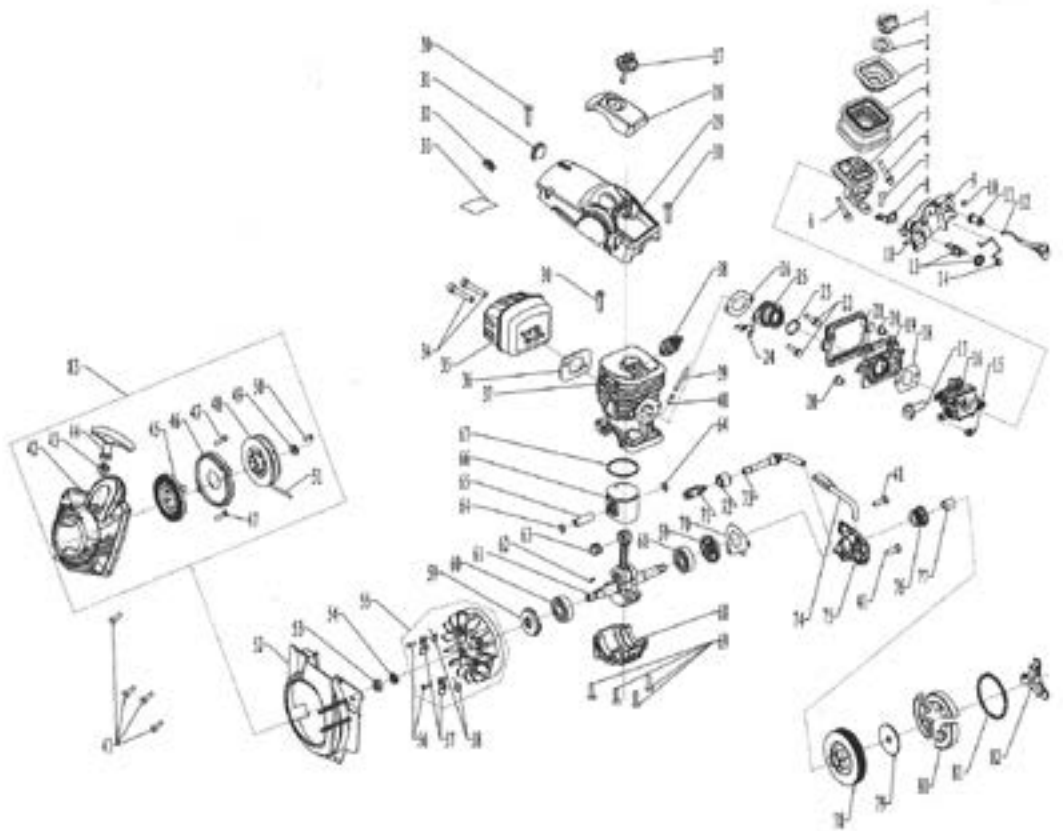

# EXPLODED DIAGRAM & PARTS LIST

PART#	SKU	DESCRIPTION	QTY
001	SP-CS-40-001	LOCK NUT	1
002	SP-CS-40-002	NYLON GASKET	1
003	SP-CS-40-003	AIR CLEANER BRACKET	1
004	SP-CS-40-004	AIR CLEANER ASSEM	1
005	SP-CS-40-005	AIR INLET CURVING PIPE	1
006	SP-CS-40-006	SCREW	2
007	SP-CS-40-007	SCREW	2
008	SP-CS-40-008	GROUND PLATE	1
009	SP-CS-40-009	CONTROL BRACKET	1
010	SP-CS-40-010	CUSHION	2
011	SP-CS-40-011	CUSHION	1
012	SP-CS-40-012	CHOKE AND ROD	1
013	SP-CS-40-013	SWITCH (ON/OFF)	1
014	SP-CS-40-014	THROTTLE ROD ASSEM	1
015	SP-CS-40-015	GUIDE (L-H)	1
016	SP-CS-40-016	CARBURETTOR	1
017	SP-CS-40-017	GUIDE	1
018	SP-CS-40-018	CARBURETTOR GASKET	1
019	SP-CS-40-019	CARBURETTOR BRACKET	1
020	SP-CS-40-020	NUT	2
021	SP-CS-40-021	CUSHION	1
022	SP-CS-40-022	SCREW	2
023	SP-CS-40-023	INLET PIPE GUIDE	1
024	SP-CS-40-024	BUSHING BRACKET	1
025	SP-CS-40-025	INLET PIPE ASSEM	1
026	SP-CS-40-026	INTAKE GASKET	1
027	SP-CS-40-027	CLEANER LID KNOB	1
028	SP-CS-40-028	AIR CLEANER COVER	1
029	SP-CS-40-029	CYLINDER COVER ASSEM	1
030	SP-CS-40-030	SCREW	3
031	SP-CS-40-031	COVER PLUG	1
032	SP-CS-40-032	HT CORD GROOMER	1
033	SP-CS-40-033	HEAT SHIELD	1
034	SP-CS-40-034	SCREW	2
035	SP-CS-40-035	MUFFLER	1
036	SP-CS-40-036	MUFFLER GASKET	1
037	SP-CS-40-037	CYLINDER	1
038	SP-CS-40-038	SPARK PLUG	1
039	SP-CS-40-039	CARBURETTOR TUBE	1
040	SP-CS-40-040	TUBE JOINTS	1
041	SP-CS-40-041	SCREW	6
042	SP-CS-40-042	STARTER COVER ASSEM	1
043	SP-CS-40-043	ROPE GUIDE	1
044	SP-CS-40-044	STARTER KNOB	1
045	SP-CS-40-045	RECOIL SPRING	1
046	SP-CS-40-046	STARTER REEL SEAT	1
047	SP-CS-40-047	SCREW	2
048	SP-CS-40-048	STARTER REEL	1
049	SP-CS-40-049	WASHER 5	1
050	SP-CS-40-050	SCREW	1
051	SP-CS-40-051	NYLON ROPE	1

PART#	SKU	DESCRIPTION	QTY
052	SP-CS-40-052	FAN COVER	1
053	SP-CS-40-053	NUT	1
054	SP-CS-40-054	SPRING WATER	1
055	SP-CS-40-055	FLYWHEEL ASSEM Y	1
056	SP-CS-40-056	SHOULDER SCREW	2
057	SP-CS-40-057	PAWL	2
058	SP-CS-40-058	SPRING	2
059	SP-CS-40-059	OIL SEAL	2
060	SP-CS-40-060	BALL BEARING	1
061	SP-CS-40-061	CRANKSHAFT COMP	1
062	SP-CS-40-062	WOODRUFF KEY	1
063	SP-CS-40-063	NEEDLE BEARING	1
064	SP-CS-40-064	CIRCLIP	2
065	SP-CS-40-065	PISTION PIN	1
066	SP-CS-40-066	PISTON ASSEM Y	1
067	SP-CS-40-067	PISTION RING	1
068	SP-CS-40-068	CRANKCASE SEAT	1
069	SP-CS-40-069	SCREW	6
070	SP-CS-40-070	OIL PUMP SEAL PLATE	1
071	SP-CS-40-071	OIL STRAINER ASSEM Y	1
072	SP-CS-40-072	OIL FILTER WEIGHT	1
073	SP-CS-40-073	OIL PUMP PIPE (I)	1
074	SP-CS-40-074	OIL PUMP PIPE (O)	1
075	SP-CS-40-075	OIL PUMP	1
076	SP-CS-40-076	NYLON WORM	1
078	SP-CS-40-078	NEEDLE BEARING	1
079	SP-CS-40-079	CLUTCH DRUM	1
080	SP-CS-40-080	WEDGE	3
081	SP-CS-40-081	CLUTCH SPRING	1
082	SP-CS-40-082	WEDGE BRACKET	1
083	SP-CS-40-083	STARTER ASSEM	1
101	SP-CS-40-101	OIL TANK CAP COMP	1
102	SP-CS-40-102	SUMP COVER WASHER	1
103	SP-CS-40-103	BREATHER PLUG	1
104	SP-CS-40-104	BREATHER	1
105	SP-CS-40-105	ENGINE COVER ASSEM Y	1
107	SP-CS-40-107	IGNITION ASSEM Y	1
108	SP-CS-40-108	DAMPING STOPPER	2
109	SP-CS-40-109	GROUND PLATE	1
110	SP-CS-40-110	NUT	2
111	SP-CS-40-111	SCREW	4
112	SP-CS-40-112	SCREW	4
113	SP-CS-40-113	GUIDE PLATE	1
114	SP-CS-40-114	SCREW	1
115	SP-CS-40-115	WIRE	1
116	SP-CS-40-116	SCREW	1
117	SP-CS-40-117	SPRING SEAT	1
118	SP-CS-40-118	SCREW	5
119	SP-CS-40-119	DAMPING SPRING	1
120	SP-CS-40-120	REAR DAMPING SPRING	2
121	SP-CS-40-121	SCREW	2

# EXPLODED DIAGRAM & PARTS LIST

PART#	SKU	DESCRIPTION	QTY
122	SP-CS-40-122	SPRING CAP	2
123	SP-CS-40-123	AIRPROOF WASHER	1
124	SP-CS-40-124	FUEL TANK CAP COMP	1
125	SP-CS-40-125	FUEL PIPE	1
126	SP-CS-40-126	FUEL PIPE BRUSHING	1
127	SP-CS-40-127	FUEL STRAINER Y	1
128	SP-CS-40-128	FUEL BREATHER ASSEM Y	1
129	SP-CS-40-129	BREATHER COVER	1
130	SP-CS-40-130	CIRCLIP	2
131	SP-CS-40-131	BREATHER PIPE	1
132	SP-CS-40-132	REAR HANDLE COMP	1
133	SP-CS-40-133	THROTTLE TRIGGER	1
134	SP-CS-40-134	PIN	1
135	SP-CS-40-135	SPRING	1
136	SP-CS-40-136	REAR HANDLE COVER	1
137	SP-CS-40-137	TRIGGER INTERLOCK ARM	1
138	SP-CS-40-138	HAND GUARD ASSEM Y	1
139	SP-CS-40-139	PIN	1
140	SP-CS-40-140	SHAFT BUSH	1
141	SP-CS-40-141	BRAKE SPRING	1
142	SP-CS-40-142	BRAKE LEVER ASSEMB Y	1
143	SP-CS-40-143	BRAKE STOPPER ASSEM Y	1
144	SP-CS-40-144	BRAKE ADJUSTER	1
145	SP-CS-40-145	TENSIONER PASSIVE BOLT	1
146	SP-CS-40-146	TENSIONER PIN	1
147	SP-CS-40-147	CHAIN TENSIONER ADJUSTER	1
148	SP-CS-40-148	BEVEL GEAR SEAT	1
149	SP-CS-40-149	BEVEL GEAR	1
150	SP-CS-40-150	SCREW	1
151	SP-CS-40-151	SPROCKET GUARD PLATE	1
152	SP-CS-40-152	BRAKE SPRING COVER	1
153	SP-CS-40-153	FLEXIBLE PIN	1
154	SP-CS-40-154	SCREW	1
155	SP-CS-40-155	SPACER	2
156	SP-CS-40-156	SPRING	1
157	SP-CS-40-157	LOCK NUT M5	1
158	SP-CS-40-158	CLUTCH COVER COMP	1
159	SP-CS-40-159	NUT M8	2
160	SP-CS-40-160	FRONT HANDLE ASSEM Y	1
161	SP-CS-40-161	GUIDED BAR	1
162	SP-CS-40-162	SAW CHAIN	1
163	SP-CS-40-163	GUIDE BAR	1
164	SP-CS-40-164	SPIKED BUMPER	1
165	SP-CS-40-165	SCREW DRIVER	1
166	SP-CS-40-166	SPARK PLUG WRENCH	1
167	SP-CS-40-167	T25 WRENCH	1
168	SP-CS-40-168	PAPER GASKET	1
169	SP-CS-40-169	GASKET	2
170	SP-CS-40-170	FUEL MIXTUR KETTLE	1
171	SP-CS-40-171	CLUTCH COVER ASSEM Y	1
172	SP-CS-40-172	INSULATION ALUMINIUM FOIL	1

PART#	SKU	DESCRIPTION	QTY
173	SP-CS-40-173	STUD	2
174	SP-CS-40-174	SAWDUST PROTECTOR	1



# YOU MAY ALSO LIKE

5 IN 1  
MULTI TOOL



MULCHER/ CHIPPER



LOG SPLITTER



CHAINSAW  
SHARPENER



Enquiry or problems with our products?

**CALL US (02) 4257 4787**



**[www.bbta.com.au](http://www.bbta.com.au)**