

# OWNER'S MANUAL

## 26cc & 52cc Brush Cutter



# OWNER'S MANUAL

Assembly & Operating Instructions

## BBT Brush Cutter

MODEL NO. BBT-BC-26CCBH

BBT-BC-26CCDH

BBT-BC-52CCBH



## To The Owner

Thank you for purchasing our Brush Cutter. It was carefully engineered to provide excellent performance when properly operated and maintained.

Please read this entire manual prior to operating the Brush Cutter. It instructs you how to safely and easily set up, operate and maintain your Brush Cutter. Please be sure that you and any other persons who will operate the Brush Cutter carefully follow the recommended safety practices at all times. Failure to do so could result in personal injury or property damage.

All information in this manual is relative to the most recent product information available at the time of printing. Review this manual frequently to familiarise yourself with the machine, its features and operation. Please be aware that this Owner's Manual may cover a range of product specifications for various models. Characteristics and features discussed and/or illustrated in this manual may not be applicable to all models. We reserve the right to change product specifications, designs and equipment without notice and without incurring obligation.

All the power testing information used to establish the power rating of the engine equipped on this Brush Cutter can be found in the engine manufacturer's manual or website. If you have any problems or questions concerning the machine, please contact our Customer Support Department.

Throughout this manual, all references to right and left side of the Brush Cutter are observed from the operating position. The engine manufacturer is responsible for all engine-related issues with regards to performance, power-rating, specifications, warranty and service. Please refer to the engine manufacturer's Owner's Manual packed separately with your Brush Cutter for more information.

## Customer Support

*Please do NOT return the Brush Cutter without first contacting the Customer Support Department at [bbt@bbta.com.au](mailto:bbt@bbta.com.au).*

If you have difficulty assembling this product or have any questions regarding the controls, operation, or maintenance of this Brush Cutter, please contact our Customer Support Department.

**SAVE THESE INSTRUCTIONS**

# TABLE OF CONTENTS

	Page(s)
To The Owner.....	2
Customer Support.....	2
<b>TABLE OF CONTENTS .....</b>	<b>3</b>
<b>IMPORTANT SAFETY INFORMATION .....</b>	<b>4-5</b>
Additional Information and Potential Changes.....	4
Key to Symbols.....	5
<b>GENERAL SAFETY RULES .....</b>	<b>6-7</b>
<b>PARTS LOCATION.....</b>	<b>8</b>
<b>ASSEMBLING .....</b>	<b>9-10</b>
Installing Plastic Shield .....	9
Blade Installation .....	9
Installing Bull Horn Handle .....	10
Installing D-Handle .....	10
<b>RULES OF SAFE OPERATION .....</b>	<b>11-15</b>
Danger Zone - An Area 15 Metres in Radius.....	11
Cutting with a Nylon Head.....	12
Cutting with a Blade.....	14
<b>PREPARING FOR OPERATIONS .....</b>	<b>16-17</b>
Engine Safety Precautions.....	16
Burns and Fires.....	16
Fuel & Oil Mixture.....	17
<b>OPERATIONS .....</b>	<b>18</b>
Engine Starting and Stopping Procedures .....	18
Hot Restart .....	18
Emergency Stop .....	18
<b>MAINTENANCE CARE .....</b>	<b>19</b>
<b>TROUBLESHOOTING.....</b>	<b>19-20</b>
<b>SPECIFICATIONS.....</b>	<b>21</b>
<b>WARRANTY &amp; SERVICE .....</b>	<b>22</b>
<b>EXPLODED DIAGRAM &amp; PARTS LIST.....</b>	<b>23-29</b>
<b>YOU MAY ALSO LIKE .....</b>	<b>30</b>



## IMPORTANT SAFETY INFORMATION



**WARNING:** Read and thoroughly understand all instructions in this manual and on the safety decals before assembling or operating this Brush Cutter. Failure to do so may cause serious injury or death. Do not allow anyone to operate this Brush Cutter who has not read this manual. As with all power equipment, a Brush Cutter can be dangerous if assembled or used improperly. Do not operate this Brush Cutter if you have any questions concerning its safe operation. To get answers to any questions, call our Customer Support Department.



This **SAFETY ALERT SYMBOL** identifies important safety messages in this manual. Failure to follow this important safety information may result in serious injury or death.



**DANGER!** This Brush Cutter was built to be operated according to the safe operation practices in this manual. As with any type of power equipment, carelessness or error on the part of the operator can result in serious injury. This Brush Cutter is capable of amputating hands and feet and throwing debris. Failure to observe the following safety instructions could result in serious injury or death.

The following signals, words and meanings are intended to explain the levels of risk associated with this product.



**DANGER**

**DANGER** indicates a hazardous situation which, if not avoided, will result in serious injury or death.



**WARNING**

**WARNING** indicates a hazardous situation which, if not avoided, could result in serious injury or death.



**CAUTION**

**CAUTION** indicates a hazardous situation which, if not avoided, could result in minor or moderate injury.

**NOTICE**

**NOTICE** is important information about the proper use of your Brush Cutter. Failure to follow this instruction could result in damage to your Brush Cutter or property.

### Additional Information and Potential Changes

We reserve the right to discontinue, change, and improve our products at any time without notice or obligation to the purchaser. The descriptions and sections contained in this manual were in effect at the time of printing. Equipment described within this manual may be optional. Some illustrations may not be applicable to your machine.

Because a trimmer/cutter is a high-speed, fast cutting power tool, special safety precaution must be observed to reduce the risk of personal injury. **Read this manual carefully.** Be familiar with the controls and the proper use of the unit. Know how to shut off your Brush Cutter and how to unhook a harnessed unit quickly



# IMPORTANT SAFETY INFORMATION

## Key to Symbols

Symbol	Description		
	<b>READ THE OWNER'S MANUAL(S)</b> Read, understand and follow all instructions in the manual(s) before attempting to assemble and operate.		
	<b>FACE PROTECTION</b> Always wear safety goggles or safety glasses with side shields or a face shield when operating this product as well as ear protection.		
	<b>WEAR GLOVES</b> Always wear non-slip, heavy-duty protective gloves when operating this product.		
	<b>WEAR SAFETY FOOTWEAR</b> Always wear non-slip steel-toed safety footwear when operating this product.		
	<b>BEWARE OF FLYING OBJECTS</b> Danger of eye injury. Wear safety glasses.		
	<b>BYSTANDERS</b> Keep bystanders, helpers and children at least 15 metres away.		
	<b>BEWARE OF SHARP BLADES</b> Serious injury is possible.		<b>BEWARE OF FALLING OBJECTS</b> Serious injury is possible.
	<b>TURN OFF ENGINE</b> Make sure the cutting tool has stopped before cleaning, removing or adjusting blade.		
	<b>NEVER MODIFY A TRIMMER OR CUTTER IN ANY WAY</b> Improper use of any trimmer can cause serious or fatal personal injury.		
	<b>BEWARE OF HAZARDOUS GASES</b> The engine exhaust from this product contains chemicals known to cause cancer, birth defects, or other reproductive harm.		
	<b>NO FIRE</b> No fire, no unprotected source of flame, no smoking.		

**WARNING!** Your Responsibility—Restrict the use of this power machine to persons who have read, understood and will follow the warnings and instructions in this manual and on the machine.

**SAVE THESE INSTRUCTIONS!**

# GENERAL SAFETY RULES

This machine can cause serious injuries. Read the instructions carefully for the correct handling, preparation, maintenance, starting and stopping of the machine. Be familiar with all controls and the proper operation of them. Know how to stop the machine and disengage them quickly.

Keep this manual in a safe place for future and regular reference and for ordering replacement parts.

Never allow children or anyone unable to fully understand the directions given in the manual to use the machine.

- Always wear safety goggles for eye protection. Dress properly; do not wear loose clothing or jewellery that could become caught in the moving parts of this unit. Safe, sturdy, non-slip footwear should always be worn. Long hair should be tied back. It is recommended that legs and feet be covered to protect from flying debris during operation.



- Inspect the entire machine for loose parts (nuts, bolts, screws, etc.) or any damage. Repair or replace as necessary before using the machine.
- **DO NOT** use any attachment with this power head other than the ones recommended by our company, otherwise this could cause serious injury to the operator or bystander, as well as damage to the machine.
- Keep the handles free from oil and fuel.
- Always use proper handles and shoulder strap when cutting.
- **DO NOT** smoke while mixing fuel or filling the tank.
- **DO NOT** mix fuel in an enclosed room or near open flames. Ensure adequate ventilation.
- Always mix and store the fuel in an approved and properly marked container that is approved by local codes and ordinances for such usage.
- **NEVER** remove the fuel tank cap while the engine is running.
- **NEVER** start or run the engine inside a closed room or building. Fumes from the exhaust contain dangerous carbon monoxide.
- **NEVER** attempt to make engine adjustments while the unit is running and strapped to the operator. Always make engine adjustments with the unit resting on a flat, clear surface.
- **DO NOT** use the unit if it is damaged or poorly adjusted. Never remove the machine's guard. This could cause serious injury to the operator or bystanders as well as damage to the machine.

- Inspect the area to be cut and remove all debris that could become tangled in the nylon cutting head. Also remove any objects that the unit may throw during cutting.
- Keep children away. Onlookers should be kept at a safe distance from the work area, at least 15 metres.
- **NEVER** leave the machine unattended.
- **DO NOT** use this unit for any job other than those for which it is intended and as described in this manual.
- **DO NOT** over reach. Keep proper footing and balance at all times.
- **DO NOT** run the unit while standing on a ladder or on any other unstable footing location.
- Keep hands and feet clear of the nylon cutting head while unit is in use.
- **DO NOT** use this type of machine for sweeping away debris.
- **DO NOT** use the unit when you are tired, ill or under the influence of medication, drugs or alcohol.
- Use nylon cutting head which is free of damage. If a stone or any other object hits the machine, stop the engine and check the nylon cutting head. A broken or unbalanced nylon cutting head must never be used.

## Instructions for Changing Accessories

- **DO NOT** store in a closed area where fuel vapours can reach an open flame from hot water heaters, heaters, etc. Store in a locked, well ventilated area only.
- To ensure safe and proper performance of your product use only the parts available from your dealer. The use of any other accessories or attachments may cause a potential hazard or injury to the user, damage to the machine and void this warranty.
- Clean the machine completely, especially the fuel tank, its surroundings, and the air filter.
- When refuelling, be sure to stop the engine and confirm that it is cooled down. Never refuel when the engine is running or hot. When fuel spills, be sure to wipe it up completely and properly dispose of those materials before starting the engine.
- Stay clear of other workers or bystanders by at least 15 metres/50 feet.
- Whenever approaching the operator of the machine, carefully call for their attention and confirm that the operator has stopped the engine. Be careful not to startle or distract the operator, this can cause an unsafe situation.
- **NEVER** touch the nylon cutting head whenever the engine is running. If it is necessary to adjust the protector or nylon cutting head, be sure to stop the engine and confirm that the nylon cutting head has completely stopped running.

# GENERAL SAFETY RULES

- The engine should be turned off when the machine is moved between work areas.
- Be careful not to hit the nylon cutting head against stones or the ground.
- Unreasonable rough operation will shorten the life of the unit and potentially create an unsafe environment for yourself and those around you.
- Pay attention to loosening and overheating of parts. If there is any abnormality of the machine, stop operation immediately and check the machine carefully. If necessary, have the machine serviced by an authorised dealer. Never continue to operate a machine which may be malfunctioning.
- In start-up or during operation, never touch hot parts such as the muffler, the high voltage wire or the spark plug.
- After the engine has stopped, take caution as the muffler is still hot. Never place the machine in any area where there are flammable materials (dry grass, etc.), combustible gasses or combustible liquids.
- Pay special attention when operating your unit in the rain or just after the rain as the ground may be slippery.
- If you slip or fall to the ground, or into a hole, release the throttle lever immediately.
- Be careful not to drop the machine or hit it against obstacles.
- Before proceeding to adjust or repair the machine, be sure to stop the engine and detach the spark plug cap from the spark plug.
- When the machine is placed in storage for a long time, drain fuel from the fuel tank and carburettor, clean the parts, move the machine to a safe place and confirm that the engine has cooled down.
- Make periodic inspections to ensure safe and efficient operation.
- Keep the machine away from fire or sparks.
- It is believed that a condition called Raynaud's phenomenon, which affects the fingers of certain individuals may be brought about by exposure to vibration and cold. Exposure to vibration and cold may cause tingling and burning sensations followed by loss of colour and numbness in the fingers.
- The following precautions are strongly recommended because the minimum exposure which might trigger the ailment is unknown.
  - a. Keep your body warm, especially the head, neck, feet, ankles, hands and wrists.
  - b. Maintain good blood circulation by performing vigorous arm exercises during frequent work breaks and also by not smoking.
  - c. Limit the hours of operation. Try to fill each day with jobs where operating the Brush Cutter or other hand-held power equipment is not required.
  - d. If you experience discomfort, redness and swelling of the fingers followed by whitening and loss of feeling, consult your physician before further exposing yourself to cold and vibration.
- Always wear ear protection, loud noises for long periods of time can make hearing debase and may even cause loss of hearing.
- Total face and head protection must be worn to prevent damage from falling branches.
- Wear non-slip heavy duty work gloves to improve your grip on the Brush Cutter handle. Gloves also reduce the transmission of machine vibration to your hands.
- The cutter area is still dangerous while the machine is coasting to a stop.

**SAFETY MANUAL included with unit**



# PARTS LOCATION

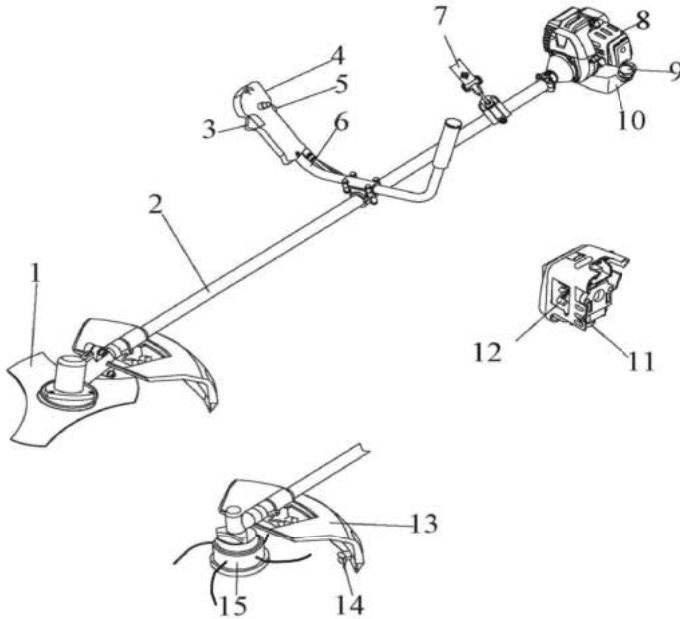

1. **BLADE:** Circular blade for grass, weed or brush cutting applications. Harness, metal shield and Bull Horn Handles/D-Handles are required for blade operation.
2. **DRIVE SHAFT ASSEMBLY:** Contains a specially designed liner, flexible drive shaft.
3. **THROTTLE TRIGGER:** Spring loaded to return to idle when released. When accelerating, press trigger gradually for best operating technique. Do not hold trigger whilst starting.
4. **IGNITION SWITCH:** "Slide switch" mounted on top of the Throttle Trigger Housing. Move switch FORWARD to RUN and BACK to STOP.
5. **SAFETY LEVER:** Before acceleration, compress this.
6. **BULL HORN/D-HANDLES:** These handles can be adjusted at your convenience for comfort.
7. **HARNES STRAP:** An attachment which hangs the machine on the operator and is adjustable in length.
8. **AIR CLEANER COVER:** Contains a replaceable felt element.
9. **FUEL TANK LID.**
10. **FUEL TANK:** For fuel and contains fuel filter.
11. **PURGE BULB:** Pushing purge bulb (7 to 10 times before starting) will remove all air and stale fuel from fuel system and bring fresh fuel to the carburettor.
12. **CHOKE:** The choke control is located on the top of the filter cover. COLD STARTS: Pull lever up to close choke for cold starts. Push lever down for RUN position.
13. **DEBRIS SHIELD:** Mounted just above the cutting attachment helps protect operator by deflecting debris produced during the trimming operation. Do not operate unit without shield.
14. **CUT-OFF KNIFE:** Trims nylon filament to the correct length 17cm, head to end of line. If trimmer is operated without a cut-off knife the line becomes too long (more than 17cm) the operating speed will slow down the engine, and will overheat or damage the engine.
15. **NYLON CUTTER HEAD:** Contains replaceable nylon trimming line that advances when the trimmer head is tapped against the ground while the head is turning at normal operating speed.

# ASSEMBLING

## Installing Plastic Shield

Install the safety cover on the shaft with the safety cover bracket and the screws provided.  
Tighten the screws after setting the safety cover bracket at the appropriate position.

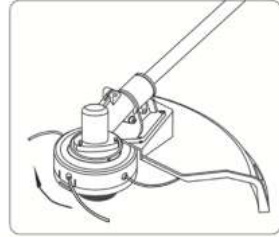
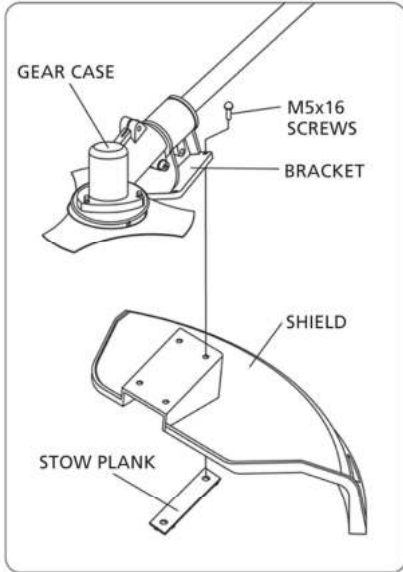

### **⚠ WARNING**

#### **INSTALLING NYLON LINE CUTTING HEAD**

Align hole in adapter plate with hole in shaft and install with lock tool.

Thread cutter head onto shaft (turning it clockwise) until it is tight. Remove locking tool.

## Blade Installation

Install holder A, the tri-blade, holder B, in this order, then clamp with a left hand thread nut.

Align hole of gear case and holder A, and insert S=4mm bar wrench.

Rotate blade-fastening nut with plug box wrench in clockwise direction until securely tightened.

### **⚠ WARNING**

#### **EXCESSIVE VIBRATION - STOP ENGINE IMMEDIATELY**

Excessive vibration of blade means that it has not been properly installed. Stop engine immediately and check blade.

Blade improperly installed will cause injury.

Use only our company's original cutting equipment parts for this unit.

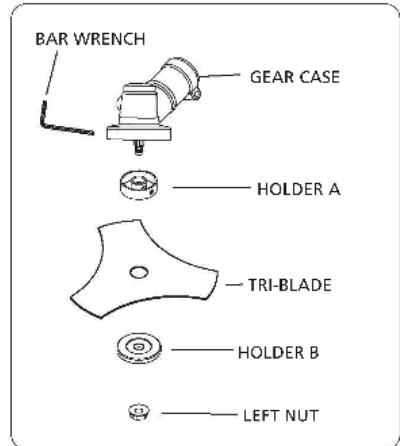

# ASSEMBLING

## Installing Bull Horn Handle

Install handle in bracket. Position handle in a comfortable operating position and tighten four M5x25 screws.

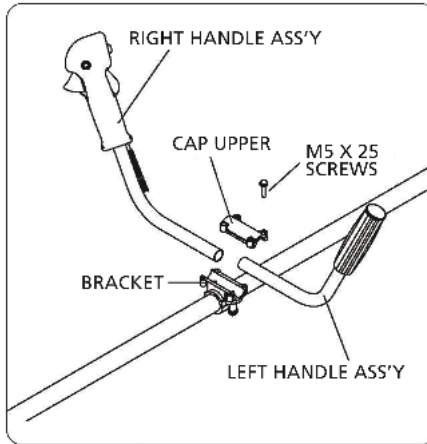

## Installing D-Handle

Install handle in bracket. Position handle in a comfortable operating position and tighten for M5 x 25 screws.

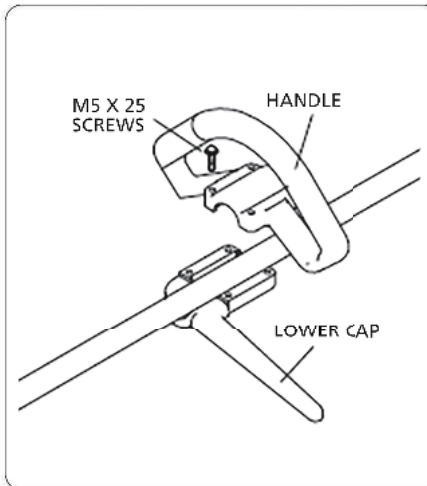

# RULES OF SAFE OPERATION



## Danger Zone - An Area 15 Metres in Radius

### **⚠ WARNING**

All models of trimmers and Brush Cutters can throw small stones, metal and other small objects as well as the material being cut. Read these *Rules of Safe Operation* with care.

Read the Owner's Manual carefully. Be thoroughly familiar with the controls and proper use of the unit.

**NEVER** allow anyone to use the unit without proper instruction. Be sure the operator wears the correct foot, leg, eye, face and hearing protection.

**DO NOT** rely on the debris shield on the unit to protect your eyes from ricocheting or thrown objects. Keep the area clear of bystanders, children and pets.

**NEVER** allow children to operate or play with the unit.

**DO NOT** allow anyone to enter the operating **DANGER ZONE** with you. The danger zone is an area 15 metres in radius (about 16 paces) or 50 feet.

Persons in the **RISK ZONE** beyond the danger zone are advised to wear eye protection from flying objects. If

the unit must be used where there are unprotected people, operate at a low throttle speed to reduce the risk of thrown objects.

Move the stop switch to "**STOP**" position when the engine idles, ensure unit is reliable before cutting.

Only continue to operate the unit when stop switch is in good working condition, routine checks for this, is if the cutting attachment stops turning when the engine idles.

### **⚠ WARNING**

In addition to wearing head, eye, face and ear protectors, ensure you wear shoes that protect your feet and improve your footing on slippery surfaces. Do not wear ties, jewellery, or loose dangling clothing which could get caught in the unit.

**DO NOT** wear open-toed footwear or go bare-foot or bare-legged. In certain situations, you must wear total face and head protection. Pay attention not to kick back and blade thrust.



NO PERSON EXCEPT OPERATOR ALLOWED WITHIN 15 METRES RADIUS DANGER ZONE. EYE, EAR, FACE, FOOT, LEG AND BODY PROTECTION MUST BE WORN BY OPERATOR. PERSONS IN ZONE OR RISK AREA BEYOND DANGER ZONE SHOULD WEAR EYE PROTECTION AGAINST THROWN OBJECTS. RISK DIMINISHES WITH DISTANCE FROM DANGER ZONE.

# RULES OF SAFE OPERATION



## Cutting with a Nylon Head

For nearly all cutting, it is good to tilt the line head so that contact is made on the part of the line circle where the line is moving AWAY from you and the debris shield. (See appropriate picture). This results in the debris being thrown AWAY from you.

### **⚠ WARNING**

The proper debris shield must be in place on the unit when nylon cutting line is used. The cutting line can flap around if too much line is exposed. Always use the plastic debris shield with cut-off knife when using nylon cutting heads.

### **⚠ WARNING**

Tilting the head to the wrong side will shoot the debris TOWARDS you. If the line head is held flat to the ground so that cutting occurs on the whole line circle, debris will be THROWN at you, drag will slow the engine down, and you will use up a lot of line.

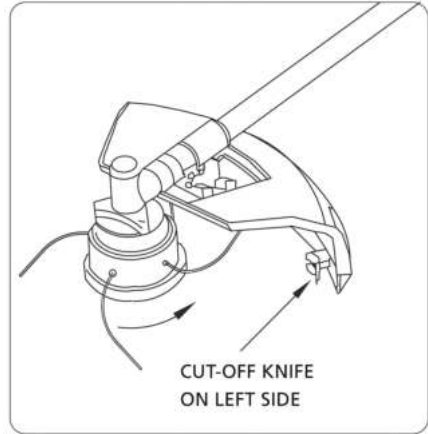

Line head rotates in a **CLOCKWISE** direction. The **CUT-OFF KNIFE** will be on the right side of the debris shield.

### **⚠ WARNING**

Use only quality nylon monofilament line of 2.5mm diameter.

**NEVER** use wire or wire-reinforced line in place of nylon trimmer line. Load your nylon line cutting head only with nylon trimmer line of the proper diameter.

### **⚠ WARNING**

Use extreme caution when operating over bare spots and gravel, because the line can throw small rock particles at high speeds.

Debris shields on the unit cannot stop objects which bounce or ricochet off hard surfaces.

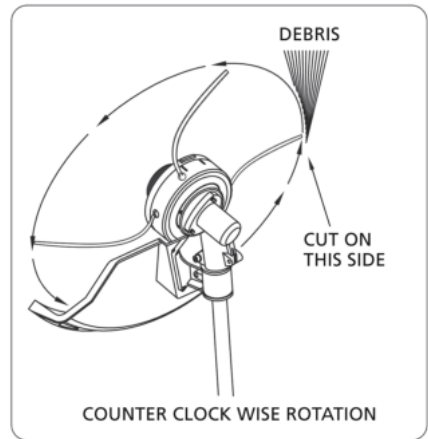

# RULES OF SAFE OPERATION

## Trimming

This is feeding the trimmer carefully into the material you wish to cut. Tilt the head slowly to direct debris away from you. If cutting up to a barrier such as a fence, wall or tree, approach from an angle where any debris ricocheting off the barrier will fly away from you. Move the line head slowly until the grass is cut right to the barrier, but do not jam (overfeed) the line into the barrier.

If trimming up to a wire mesh or chain linked fence, be careful to feed only up to the wire. If you go to too far the line will snap off around the wire.

Trimming can be done to cut through weed stems one at a time. Place the trimmer line head near the bottom of the weed, never high up which could cause the weed to catch the line. Rather than cut the weed right through, just use the very end of the line to wear through the stem slowly.

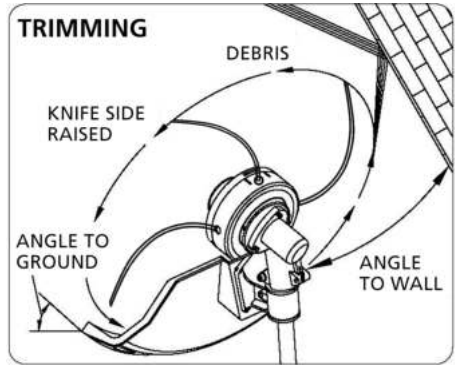

## ⚠ WARNING

**DO NOT** use a steel blade for edging or scalping.

## Scalping and Edging

Both of these are done with the line head tilted at a steep angle. Scalping is removing top growth leaving the earth bare.

Edging is trimming the grass back where it has spread over a sidewalk or driveway.

During both edging and scalping, hold the unit at a steep angle and in a position where the debris, and any dislodging dirt and stones, will not come back towards you even if it ricochets off the hard surface. Although the picture shows how to edge and scalp, every operator must find for themselves the angles which suits their body size and cutting situation.



## ⚠ WARNING

**DO NOT** trim in any area where there are strands of fencing wire. Wear protective safety clothing.

**DO NOT** cut where you cannot see what the cutting device is cutting.

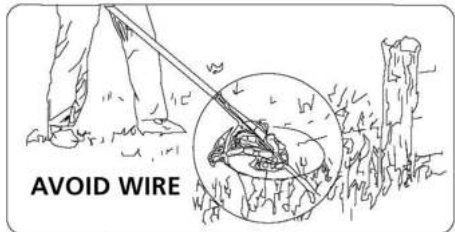

# RULES OF SAFE OPERATION



## Cutting with a Blade

### ⚠ WARNING

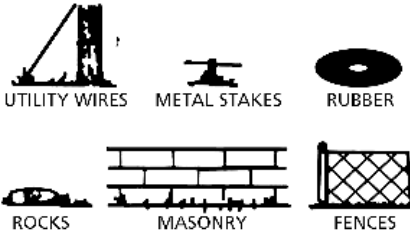

**DO NOT TOUCH**  
THESE TYPES OF OBJECTS WITH BLADE

### ⚠ WARNING

DO NOT cut with a dull, cracked or damaged metal blade. Before cutting growth, inspect for obstructions such as boulders, metal stakes or strands of wire from broken fences. If an obstruction cannot be removed, mark its location so that you can avoid it with the blade. Rocks and metal will dull or damage a blade. Wires can catch on the blade head and flap around or be thrown into the air.

## Scything Weeds

This is cutting by swinging the blade in a level arc. It can quickly clear areas of field grass and weeds. Scything should not be used to cut large, tough weeds or woody growths.

**NOTE: DO NOT** use a brush blade to cut trees which exceed a diameter of 1/2 to 3/4 inches.

Scything can be done in both directions, or just one way which results in the debris being thrown away from you.

**NOTE:** You will be hit by some debris if you scythe in both directions.

### ⚠ WARNING

Use the shoulder harness at all times. Adjust both harness and harness clamp on the unit so that the unit hangs a few inches above ground level. The cutting head and the metal debris shield should be level in all directions. Harness the unit on the right side of your body.

### ⚠ WARNING

**DO NOT USE A BRUSH CUTTER FOR CUTTING TREES**

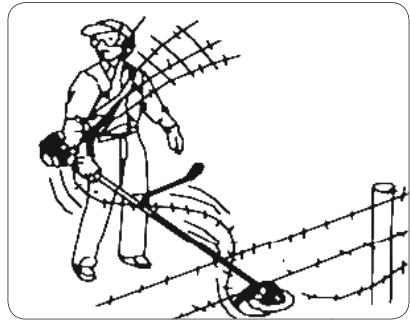

# RULES OF SAFE OPERATION

## Sawing

This must be done with a saw blade when the weeds are too thick and strong for scything.

If kickback occurs, the blade may be dull, or the material is too thick and hard that you should use a saw blade instead of the brush blade.

Growth up to 75mm in diameter, which is too thick for scything, may be cut by sawing. Sawing requires judgement on your part whether to cut on the side where the blade pulls away from you but throws back

the debris, or on the side where the debris is thrown away from you but the reaction is to push which could cause a kickout (blade thrust).

Always cut on the side of the tree which will cause the tree to fall away from the unit. A kickout may result if the tree falls toward the unit and pinches the blade.

Do not force the blade to cut. Do not change the angle of cut after blade is in the wood. Avoid using any pressure or leverage which could cause the blade to bend or crack.

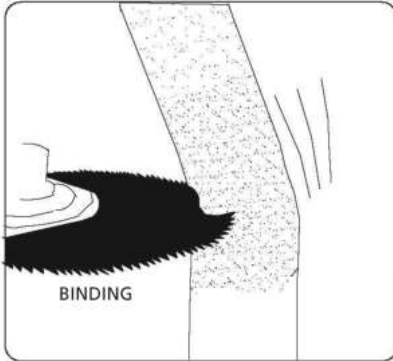



# PREPARING FOR OPERATIONS

## Engine Safety Precautions

### Warning Carbon Monoxide Poisoning

All engines contain carbon monoxide in their exhaust. Carbon monoxide is a deadly, colourless, tasteless, odourless gas which may be present even if you do not smell or see any engine exhaust. Levels of carbon monoxide, which can be deadly, can be present for days in an enclosed area that has poor ventilation. Any level of carbon monoxide, if inhaled, can cause headaches, drowsiness, nausea, dizziness, confusion and eventually death. **If you experience any of these symptoms, seek fresh air and medical attention immediately.**

### Preventing Carbon Monoxide Poisoning

- **Never** run engine indoors.
- Carbon monoxide can reach dangerous levels very quickly.
- **Never** run engine outdoors where exhaust fumes may be pulled into a building.
- **Never** run engine outdoors in a poorly ventilated area where the exhaust fumes may be trapped and not easily taken away. (Examples include: in a large hole or areas where hills surround your working area.)
- **Never** run engine in an enclosed or partially enclosed area. (Examples include: buildings that are enclosed on one or more sides, under tents, carports or basements.)
- Always run the engine with the exhaust and muffler pointed in the direction away from the operator.
- **Never** point the exhaust muffler towards anyone. People should always remain a safe distance away from the operation of the engine and its attachments.

### Petrol Fires and Handling Fuel Safely

Fuel and fuel vapours are highly flammable. Never use fuel where a spark or flame may be present. Never use fuel where a potential source of ignition could occur. (Examples include: hot water systems, clothes dryer or electric motors, etc.)

Keep flames and sparks away from engine and fuel to prevent fires. Fuel fires spread very quickly and are highly explosive.

### Prevention of Petrol Fires

- **Never** fill your fuel tank with fuel indoors. (Examples include: garage, shed, house, porch, etc.)
- Always fill fuel tank outside in a well ventilated area.
- **Never** remove the fuel cap or add fuel with the engine running. Stop engine and allow to cool before filling.
- **Never** drain fuel from engine in an enclosed area.

- Always wipe up excess (spilled) fuel from engine before starting. Clean up spilled fuel immediately.
- Allow spilled fuel to dry, after wiping and before starting.
- Allow fuel fumes/vapours to escape from the area before starting engine.
- Test the fuel cap for proper installation before starting and using engine.
- Always run the engine with fuel cap properly installed on the engine.
- Replace fuel cap if it allows fuel to spill or leak.
- **Never** smoke while refilling engine fuel tank.
- Prevent fire and explosion caused by static electric discharge. Use only non-metal, portable approved fuel containers.
- **Do not** store engine with fuel in fuel tank indoors. Fuel and fuel vapours are highly explosive.
- When storing, screw down fuel cap vent tightly.
- **Never** pour fuel from engine fuel tank.
- **Never** siphon fuel by mouth to drain fuel tank.
- Always have an adult fill the fuel tank.
- **Never** allow an adult or anyone under the influence of drugs or alcohol to fill engine.
- **Never** allow children to fill the engine.

## Burns and Fires

The muffler, muffler guard and other parts of the engine become extremely hot during the operation of the engine. These parts remain extremely hot even after the engine has stopped.

### Prevention of Burns and Fires

- **Never** remove the muffler guard from the engine.
- **Never** touch the muffler guard as it is extremely hot and will cause severe burns.
- **Never** touch parts of the engine that become hot after operation.
- Always keep materials and debris away from muffler guard and other hot parts of the engine to avoid fires.

### CAUTION

Hot gases are a normal by-product of a functioning catalytic converter. Follow all safety instructions to prevent burns and fires.

# PREPARING FOR OPERATIONS

## Fuel & Oil Mixture

The fuel and oil mixture of 25:1 only applies if your unit is a 2-stroke engine, these include the 26cc, 33cc and 52cc engines.

### WARNING

- **NEVER** fill the fuel tank to the very top.
- **NEVER** add fuel to the tank in a closed non-ventilated area.
- **DO NOT** add fuel to this unit close to an open fire or sparks.
- Be sure to wipe off spilled fuel before attempting to start engine.
- **DO NOT** attempt to refuel a hot engine.

Fuel used for this model is a mixture of unleaded petrol and approved engine lubricant. When mixing petrol with 2-stroke engine oil, use only petrol which contains NO ETHANOL or METHANOL (types of alcohol). Use branded 89 octane or higher unleaded petrol known to be of good quality. This will help avoid possible damage to engine fuel lines and other engine parts.

Fuel mixed at a rate other than 25:1 may cause damage to the engine, ensure mixture ratio is correct.



OIL – 1 PART

PETROL - 25 PART

### Petrol

Use branded 89 octane or higher unleaded fuel known to be of good quality.

### Storing Fuel

Store fuel only in a clean, safe, approved container. Check and follow local ordinances on type and location of storage container.

### Fuel and Oil Mixture

Inspect fuel tank making sure that it is clean and filled with fresh fuel. Use a mixture of 25:1 for 2-stroke only.

**IMPORTANT:** 2-stroke fuel may separate. Shake fuel container thoroughly before each use.

Stored fuel ages. Do not mix more fuel than you expect to use within a month.

**IMPORTANT:** Failure to follow proper fuel mix instructions may cause damage to the engine.

### Check Points Before Operation

1. Check for loose bolts, nuts and fittings.
2. Check the air filter for dirt. Clean the air filter of all dirt, etc. before operation.
3. Check that protector is securely in place.
4. Check that fuel is not leaking.
5. Check that blades are not cracked.

### WARNING

The engine exhaust from this product contains chemicals known to cause cancer, birth defects, or other reproductive harm.

# OPERATIONS



## Engine Starting and Stopping Procedures

### Starting Cold Engine

1. Move the stop switch to START position.
2. Give a gentle push on the primer pump repeatedly (7-10 times) until fuel comes into the primer pump.
3. Cold Starts: Pull lever up to close choke.
4. Pull starter handle until engine false fires.
5. To start a cold engine, move the choke lever to CLOSED (up position).
6. Pull the pull start handle out until you feel resistance, then pull firmly, allowing the pull start cord to return gently.
7. Pull the start handle until engine starts.
8. If the choke was engaged while starting the engine, slowly disengage the choke to the CLOSED position as the engine begins to fire.
9. Allow engine to warm up for a few minutes before using.

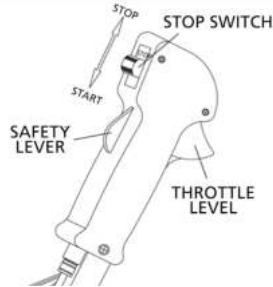

### Starting Warm Engine

- If fuel tank was not run dry, pull starter one to three times and engine should start.

### Do Not Use Choke

- If fuel tank was run dry, after refilling repeat steps 3 to 7 in Starting Cold Engine.

### Stopping the Engine

- Move switch to STOP position.

### Hot Restart

If the engine is operated at above ambient temperature, then turned off and allowed to sit for a while, it may not start again on the first pull and the starting procedure may need to be restarted.

### Emergency Stop

To stop the engine in an emergency, simply flick the switch on the handle into the OFF position. Although under regular conditions, you should fully release the throttle and wait until engine slows down to idle speed before stopping the engine, as stopping the engine at full revs can be damaging.

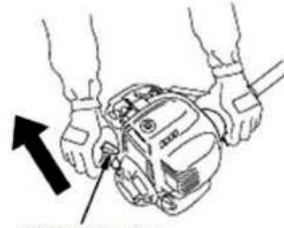
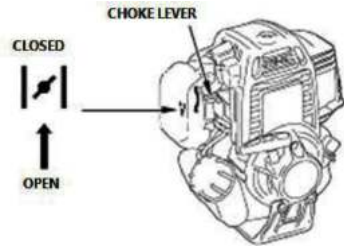

**NOTE:** Do not allow the starter grip to snap back against the engine. Return it gently to prevent damage to the starter.

### WARNING

Any level of carbon monoxide, if inhaled, can cause headaches, drowsiness, nausea, dizziness, confusion and eventually death.

Avoid any areas or actions that expose you to carbon monoxide.

# MAINTENANCE CARE

## Air Filter

- Accumulated dust in the air filter will reduce engine efficiency. Increase fuel consumption and allow abrasive particles to pass into the engine. Remove the air filter as often as necessary to maintain in a clean condition.
- Light surface dust can readily be removed by tapping the filter. Heavy deposits should be washed out in suitable solvent.
- Remove filter cover by loosening air filter cover knob.

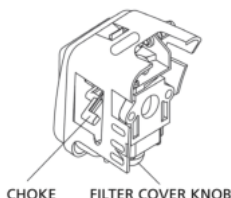

## Adjusting Carburettor

**NOTE:** Do not adjust carburettor unless necessary. Improper adjustment may cause engine damage and void warranty.

## Fuel Filter

- Fuel tank is fitted with a filter.
- Filter is situated at the free end of fuel pipe and can be picked out through fuel port with a piece of hooked wire or something similar.
- Check the fuel filter periodically. Do not allow dust to enter into fuel tank. A clogged filter will cause difficulty in starting engine or abnormalities in the engines performance.
- When filter is dirty, replace the filter.
- When the inside of the fuel tank is dirty, it can be cleaned by rinsing the tank out with petrol.

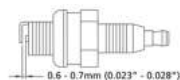
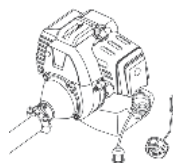

## Check Spark Plug

- Do not attempt to remove the plug from a hot engine as this could cause damage to the threads.

# TROUBLESHOOTING

- Clean or replace the plug if fouled with heavy oily deposits.
- Replace the plug if the centre electrode is worn rounded at the end.
- Spark gap 0.6-0.7mm (.023".028")
- Fastening torque =145-155kg.cm(125-135in.lb)

## Transport and Handling

- Secure the power unit during transport to prevent loss of fuel, damage or injury.
- The engine should be turned off when the unit is moved between work areas.
- After the engine has stopped, the muffler will still be hot. Never touch hot parts such as the muffler.
- Confirm that the fuel is not leaking from the tank.

## Extended Storage

- Inspect, clean and repair unit if necessary.
- Remove all fuel from tank.
- Start engine - this will consume all fuel in fuel line and carburettor.
- Remove spark plug and pour one teaspoon of clean motor oil into spark plug hole of cylinder. Replace spark plug.
- Store in clean, dry, dust free area.

**FAILURES**, such as difficulty in starting engine, irregularity in functions and abnormality in performance can normally be prevented if careful attention is paid to all operating instructions and maintenance procedures. Should the engine not function properly, check the following:

- That the fuel system is in good condition and fuel is flowing to the engine.
- The ignition system is in good condition and the spark plug sparks correctly.
- Compression of the engine is adequate.

## Failure To Start

- Dispose of fuel in tank.
- Ensure that fuel is fresh and clean.
- Check fuel filter to make sure it is clean. (Replace filter if necessary).
- Make sure air filter elements are clean.
- Install new, properly gapped spark plug.
- When there is serious trouble with the unit, do not try to repair it yourself.

# TROUBLESHOOTING

## 1. Failure to Start

CHECK		PROBABLE CAUSES		ACTION	
Cylinder Compress Pressure Normal	Spark Plug Spark normal	Fuel System abnormality		There is no fuel in tank Fuel filter obstruction	Add fuel in tank Clean fuel filter
		Fuel System abnormality	Fuel	Fuel is too dirty There is water in fuel There is too much fuel in cylinder Mixture ratio is incorrect	Replace fuel Replace fuel Tear down spark plug and dry it  Mixture proportion
	Fuel System Normal	High Voltage Wire Spark Normal	Spark plug	Spark plug fouled with oily deposits Spark plug insulation damage Spark plug gap is too large or small	Clean the oily deposits  Replace spark plug Adjust spark plug gap 0.6-0.7mm
				High Voltage Wire Spark Abnormality	High voltage wire breach or break off Coil looseness
Fuel System Normal	Ignition System Normal	Compress is shortage		Piston ring attrite Piston ring is broken Piston ring cementation Spark plug looseness Conjoint surface of the cylinder and crankcase leak	Replace with new Replace Eliminate Tighten Eliminate
		Compress Normal		High voltage wire and spark plug contact bad Stop switch failure or short circuit	Tighten the spark plug cap  Repair or replace

## 2. Low Output

CHECK	PROBABLE CAUSES	ACTION
Flameout when speedup	Fuel filter obstruct, fall short of fuel	Clean fuel filter, adjust carburettor
The smoke is thin	Muffler fouled with oily deposits	Clean the oily deposits
Compression shortage	Piston, piston ring, cylinder attrite	Replace piston, piston ring
Engine leak	Conjoint surface of the cylinder and crankcase leak	Repair
Rocket cover leak	The seal is bad	Replace seal
	Engine overheats burning, room fouled with oily deposits	Avoid using for long periods of time, high speed and heavy load, clean the oily deposits

## 3. Engine Running Unstable

CHECK	PROBABLE CAUSES	ACTION
There is a knock sound in engine	Piston, piston ring, cylinder attrite Piston pin, piston attrite Bearing of crankshaft attrite	Replace piston, piston ring Replace piston pin, piston Replace bearing
There is a metal knock sound	Engine overheats Burning, room fouled with oily deposits Fuel brand is unfit	Avoid using for long periods of time or high speed and heavy load Clean the oily deposits Replace require branded octane
Engine ignition break off	There is water in fuel Spark plug gap is wrong Coil gap is wrong	Replace fuel Adjust spark gap 0.6-0.7mm Adjust coil gap 0.3-0.4mm

## 4. The Engine Suddenly Stopped

PROBABLE CAUSES	ACTION
Fuel is empty Spark plug fouled with oily deposits and short circuit High voltage wire disconnected off	Add fuel Clean the oily deposits Connect

# SPECIFICATIONS

Engine	26cc	52cc
Type	Air-cooled; 2-stroke vertical Piston valve	Air-cooled; 2-stroke vertical Piston valve
Displacement	26cc	52cc
Max. Output	0.75/6500 kW/r/min	1.8kw at 7,000 rpm
Max. Torque	N/A	1.9Nm at 5,500 rpm
Carburettor	Diaphragm-type	Diaphragm-type
Ignition	Non-contact electronic ignition	Non-contact electronic ignition
Starter Type	Recoil Start	Recoil Start
Fuel used	Fuel mixed with lubricating oil (ratio of 25:1)	Fuel mixed with lubricating oil (ratio of 25:1)
Fuel tank capacity	Approx. 500ml	Approx. 650ml
Fuel Consumption	N/A	360g / kWh
Oil Type	2-stroke	2-stroke
Oil Capacity	N/A	N/A
Maximum speed of gear shaft /engine speed	7000/9000 r/min	7000/9000 r/min
Idle speed	3000 r/min	3000 r/min
Vibration values at each handle	≤15 m/s	≤15 m/s
Sound pressure values	≤102 dB(A)	≤102 dB(A)
Reduction ratio	7:9	7:9
Blade rotation direction	Counter-Clockwise (seen from the top)	Anti-clockwise (seen from the top)
Type of handle	Double grip/D-handle	Double grip/D-handle
Length of main pipe section	1460 mm	1460 mm
Length of drive shaft section	1500 mm	1500 mm
Standard blades	BG415-23-blade(230×1.4) mm	BG415-23-blade(230×1.4) mm

Technical Data subject to change without notice.

# WARRANTY & SERVICE

## Warranties

Bigger Boyz Toyz offer a 1-year parts warranty on all products used for domestic use from the date of purchase. For all commercial use, a 3-month parts warranty period applies, unless specified in the item listing. All conditions below are based upon the product being faulty or not performing as described. In the instance where a return is required, the purchaser is liable for any shipping cost. Warranties will only be determined by a Bigger Boyz Toyz Technician upon inspection.

Warranties do not cover accidents, misuse, neglect, natural disaster or act of God or other external causes, or damage caused by operating the equipment in a manner that is not described in the instructions.

Our products come with guarantees that cannot be excluded under the Australian Consumer Law. You are entitled to a replacement or refund for a major failure and for compensation for any other reasonably foreseeable loss or damage. You are also entitled to have the goods repaired or replaced if the goods fail to be of acceptable quality and the failure does not amount to a major failure.

Parts purchases, consumable components and accessories such as chains, carry bags, batteries, hoses, grinding discs, covers, belts, cable, wheels and blades are not covered by standard warranty.

## Spare Parts

Spare parts are available. Please see our website ([www.bbta.com.au](http://www.bbta.com.au)) or contact us at [bbt@bbta.com.au](mailto:bbt@bbta.com.au) for more details.

# EXPLODED DIAGRAM & PARTS LIST

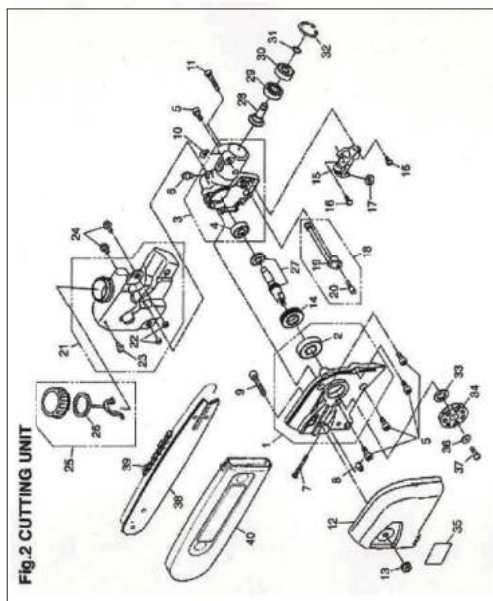
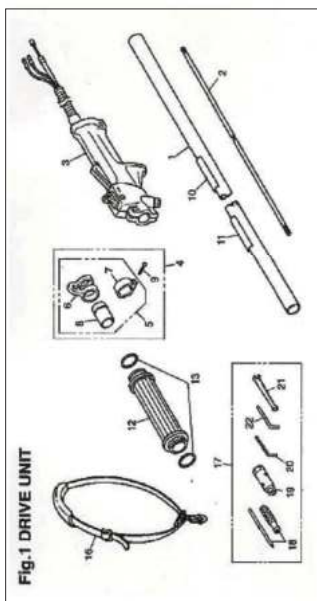
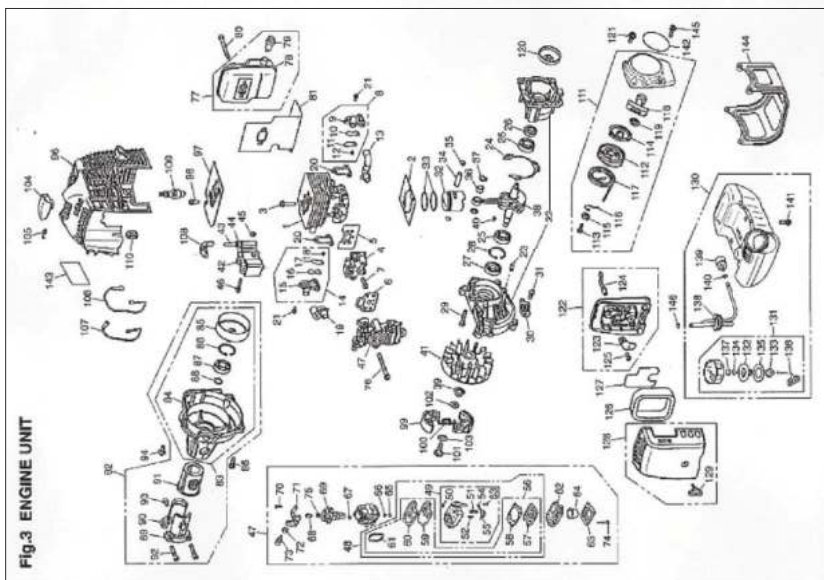



# EXPLODED DIAGRAM & PARTS LIST

## Drive Unit

NO	SKU	DESCRIPTION	QTY
1	SP-BC-26CC-001	PIPE COMP	1
2	SP-BC-26CC-002	SHAFT	1
3	SP-BC-26CC-003	GRIP ASSEM	1
4	SP-BC-26CC-004	HANGER ASSEM	1
5	SP-BC-26CC-005	HANGER COMP	1
6	SP-BC-26CC-006	HANGER	1
7	SP-BC-26CC-007	CLAMP	1
8	SP-BC-26CC-008	SLEEVE	1
9	SP-BC-26CC-009	SCREW	1
10	SP-BC-26CC-010	NAME PLATE	1

NO	SKU	DESCRIPTION	QTY
11	SP-BC-26CC-011	CAUTION PLATE	1
12	SP-BC-26CC-012	GRIP	1
13	SP-BC-26CC-013	SPRING	2
16	SP-BC-26CC-016	STRAP ASSEM	1
17	SP-BC-26CC-017	TOOL SET	1
18	SP-BC-26CC-018	DRIVER	1
19	SP-BC-26CC-019	SOCKET	1
20	SP-BC-26CC-020	WRENCH	1
21	SP-BC-26CC-021	SPANNER	1
22	SP-BC-26CC-022	BAR	1

## Cutting Unit

NO	SKU	DESCRIPTION	QTY
1	SP-BC-26CC-001.2	GEAR CASE L COMP	1
2	SP-BC-26CC-002.2	BEARING	1
3	SP-BC-26CC-003.2	GEAR CASE R COMP	1
4	SP-BC-26CC-004.2	BEARING	2
5	SP-BC-26CC-005.2	BOLT	5
6	SP-BC-26CC-006.2	FITTING	1
7	SP-BC-26CC-007.2	SCREW TENSIONER	1
8	SP-BC-26CC-008.2	NUT TENSIONER	1
9	SP-BC-26CC-009.2	BOLT	1
10	SP-BC-26CC-010.2	SHIM	1
11	SP-BC-26CC-011.2	BOLT	1
12	SP-BC-26CC-012.2	CHAIN COVER	1
13	SP-BC-26CC-013.2	NUT	1
14	SP-BC-26CC-014.2	WARM GEAR	1
15	SP-BC-26CC-015.2	OIL PUMP ASSEM	1
16	SP-BC-26CC-016.2	SCREW	2
17	SP-BC-26CC-017.2	GASKET	1
18	SP-BC-26CC-018.2	OIL PIPE ASSEM	1
19	SP-BC-26CC-019.2	OIL PIPE	1
20	SP-BC-26CC-020.2	FILTER	1

NO	SKU	DESCRIPTION	QTY
21	SP-BC-26CC-021.2	OIL TANK ASSEM	1
22	SP-BC-26CC-022.2	COLLAR	2
23	SP-BC-26CC-023.2	VALVE	1
24	SP-BC-26CC-024.2	SCREW	2
25	SP-BC-26CC-025.2	OIL CAP ASSEM	1
26	SP-BC-26CC-026.2	GASKET OIL CAP	1
27	SP-BC-26CC-027.2	GEAR SHAFT	1
28	SP-BC-26CC-028.2	BEVEL	1
29	SP-BC-26CC-029.2	BEARING	1
30	SP-BC-26CC-030.2	BEARING	1
31	SP-BC-26CC-031.2	SNAP RING	1
32	SP-BC-26CC-032.2	SNAP RING	1
33	SP-BC-26CC-033.2	COLLAR	1
34	SP-BC-26CC-034.2	SPROCKET	1
35	SP-BC-26CC-035.2	LABEL	1
36	SP-BC-26CC-036.2	WASHER	1
37	SP-BC-26CC-037.2	SCREW	1
38	SP-BC-26CC-038.2	BAR 10"	1
39	SP-BC-26CC-039.2	CHAIN 90SG - J39E	1
40	SP-BC-26CC-040.2	PROJECTOR	1

## Engine Unit

NO	SKU	DESCRIPTION	QTY
1	SP-BC-26CC-001.3	CYLINDER	1
2	SP-BC-26CC-002.3	GASKET BASE	1
3	SP-BC-26CC-003.3	BOLT M5 X 22	2
4	SP-BC-26CC-004.3	INSULATOR	1
5	SP-BC-26CC-005.3	GASKET INSULATOR	1
6	SP-BC-26CC-006.3	GASKET CARBURETTOR	1
7	SP-BC-26CC-007.3	SCREW M5 X 20	2
8	SP-BC-26CC-008.3	REEDVALVE ASSEM (S)	1
9	SP-BC-26CC-009.3	VALUE CASE	1
10	SP-BC-26CC-010.3	REEDVALVE	1
11	SP-BC-26CC-011.3	STOPPER	1
12	SP-BC-26CC-012.3	SCREW M3 X 8	1
13	SP-BC-26CC-013.3	PIPE AIR	1
14	SP-BC-26CC-014.3	REEDVALVE ASSEM (F)	1
15	SP-BC-26CC-015.3	VALUECASE (F)	1
16	SP-BC-26CC-016.3	REED VALVE	1
17	SP-BC-26CC-017.3	STOPPER	1
18	SP-BC-26CC-018.3	SCREW M3 X 8	1

NO	SKU	DESCRIPTION	QTY
19	SP-BC-26CC-019.3	PIPE AIR	1
20	SP-BC-26CC-020.3	GASKET VALVE	2
21	SP-BC-26CC-021.3	SCREW	6
22	SP-BC-26CC-022.3	CRANKCASE COMP	1
23	SP-BC-26CC-023.3	PIN	3
24	SP-BC-26CC-024.3	GASKET	1
25	SP-BC-26CC-025.3	BEARING	2
26	SP-BC-26CC-026.3	SEAL	1
27	SP-BC-26CC-027.3	SEAL	1
28	SP-BC-26CC-028.3	SNAP RING	1
29	SP-BC-26CC-029.3	BOLT M5 X 30	3
30	SP-BC-26CC-030.3	GUARD	1
31	SP-BC-26CC-031.3	SCREW M5 X 10	1
32	SP-BC-26CC-032.3	PISTON	1
33	SP-BC-26CC-033.3	RING	2
34	SP-BC-26CC-034.3	PIN	1
35	SP-BC-26CC-035.3	RING	2
36	SP-BC-26CC-036.3	BEARING	1

# EXPLODED DIAGRAM & PARTS LIST

## Engine Unit (Cont.)

NO	SKU	DESCRIPTION	QTY
37	SP-BC-26CC-037.3	WASHER	2
38	SP-BC-26CC-038.3	CRANKSHAFT COMP	1
39	SP-BC-26CC-039.3	NUT	1
40	SP-BC-26CC-040.3	KEY	1
41	SP-BC-26CC-041.3	ROTOR	1
42	SP-BC-26CC-042.3	COIL ASSEM	1
43	SP-BC-26CC-043.3	CORD	1
44	SP-BC-26CC-044.3	CAP	1
45	SP-BC-26CC-045.3	SPACER	2
46	SP-BC-26CC-046.3	BOLT M4 X 22	2
47	SP-BC-26CC-047.3	CARBURETTOR ASSEM	1
48	SP-BC-26CC-048.3	RE BUILD KIT	1
49	SP-BC-26CC-049.3	BODY ASSEM	1
50	SP-BC-26CC-050.3	SCREEN	
51	SP-BC-26CC-051.3	VALVE	
52	SP-BC-26CC-052.3	SPRING	-
53	SP-BC-26CC-053.3	SCREW	-
54	SP-BC-26CC-054.3	PIN	-
55	SP-BC-26CC-055.3	LEVER	-
56	SP-BC-26CC-056.3	GASKET KIT	1
57	SP-BC-26CC-057.3	DIAPHRAM	-
58	SP-BC-26CC-058.3	GASKET	-
59	SP-BC-26CC-059.3	DIAPHRAM PUMP	-
60	SP-BC-26CC-060.3	GASKET PUMP	-
61	SP-BC-26CC-061.3	RING	1
62	SP-BC-26CC-062.3	BODY PURGE	1
63	SP-BC-26CC-063.3	COVER PUMP	1
64	SP-BC-26CC-064.3	PUMP PRIMING	1
65	SP-BC-26CC-065.3	JET	1
66	SP-BC-26CC-066.3	O RING	1
67	SP-BC-26CC-067.3	RING	1
68	SP-BC-26CC-068.3	SWIVEL	1
69	SP-BC-26CC-069.3	VALVE ASSEM	-
70	SP-BC-26CC-070.3	SCREW	2
71	SP-BC-26CC-071.3	BRACKET	1
72	SP-BC-26CC-072.3	NUT ADJUSTER	1
73	SP-BC-26CC-073.3	SCREW ADJUSTER	1
74	SP-BC-26CC-074.3	SCREW	4
75	SP-BC-26CC-075.3	WASHER	1
76	SP-BC-26CC-076.3	SCREW M5 X 60	2
77	SP-BC-26CC-077.3	MUFFLER ASSEM	1
78	SP-BC-26CC-078.3	MUFFLER	1
79	SP-BC-26CC-079.3	ARRESTER	1
80	SP-BC-26CC-080.3	BOLT M5 X 50	2
81	SP-BC-26CC-081.3	GASKET	1
82	SP-BC-26CC-082.3	COVER ASSEM	1
83	SP-BC-26CC-083.3	COVER COMP	1
84	SP-BC-26CC-084.3	COVER BIN	1
85	SP-BC-26CC-085.3	DRUM	1
86	SP-BC-26CC-086.3	SNAPRING	1
87	SP-BC-26CC-087.3	BEARING	1
88	SP-BC-26CC-088.3	SNAP RING	1
89	SP-BC-26CC-089.3	BRACKET (A)	1
90	SP-BC-26CC-090.3	BRACKET (B)	1
91	SP-BC-26CC-091.3	CUSHION	1

NO	SKU	DESCRIPTION	QTY
92	SP-BC-26CC-092.3	BOLT M5 X 30	2
93	SP-BC-26CC-093.3	BOLT M5 X 14	1
94	SP-BC-26CC-094.3	SCREW M5 X 16	1
95	SP-BC-26CC-095.3	SCREW M5 X 20	4
96	SP-BC-26CC-096.3	COVER ENGINE	1
97	SP-BC-26CC-097.3	PLATE	1
98	SP-BC-26CC-098.3	SCREW M5X 10	2
99	SP-BC-26CC-099.3	SHOE	2
100	SP-BC-26CC-100.3	SPRING	1
101	SP-BC-26CC-101.3	SCREW	2
102	SP-BC-26CC-102.3	WASHER	2
103	SP-BC-26CC-103.3	WASHER	2
104	SP-BC-26CC-104.3	CAP	1
105	SP-BC-26CC-105.3	SPRING	1
106	SP-BC-26CC-106.3	CORD	1
107	SP-BC-26CC-107.3	CORD EARTH	1
108	SP-BC-26CC-108.3	TUBE	1
109	SP-BC-26CC-109.3	PLUG	1
110	SP-BC-26CC-110.3	GROMMET	1
111	SP-BC-26CC-111.3	RECOIL ASSEM	1
112	SP-BC-26CC-112.3	REEL	1
113	SP-BC-26CC-113.3	SCREW	1
114	SP-BC-26CC-114.3	SPRING SPIRAL	1
115	SP-BC-26CC-115.3	COLLAR	1
116	SP-BC-26CC-116.3	ARM	1
117	SP-BC-26CC-117.3	ROPE	1
118	SP-BC-26CC-118.3	KNOB	1
119	SP-BC-26CC-119.3	PLATE STOPPER	1
120	SP-BC-26CC-120.3	PULLEY	1
121	SP-BC-26CC-121.3	SCREW M5X16	2
122	SP-BC-26CC-122.3	BODY ASSES	1
123	SP-BC-26CC-123.3	PLATE CHOKE	1
124	SP-BC-26CC-124.3	LEVER CHOKE	1
125	SP-BC-26CC-125.3	SCREW	1
126	SP-BC-26CC-126.3	ELEMENT	1
127	SP-BC-26CC-127.3	SCREEN	1
128	SP-BC-26CC-128.3	COVER ASSEM	1
129	SP-BC-26CC-129.3	KNOB	1
130	SP-BC-26CC-130.3	TANK ASSEM	1
131	SP-BC-26CC-131.3	CAP ASSEM	1
132	SP-BC-26CC-132.3	HOLDER	1
133	SP-BC-26CC-133.3	CAP	1
134	SP-BC-26CC-134.3	VALUE	1
135	SP-BC-26CC-135.3	PACKING	1
136	SP-BC-26CC-136.3	STOPPER	1
137	SP-BC-26CC-137.3	FILTER	1
138	SP-BC-26CC-138.3	PIPE COMP	1
139	SP-BC-26CC-139.3	FILTER ASSEM	1
140	SP-BC-26CC-140.3	CLIP	1
141	SP-BC-26CC-141.3	SCREW M5 X 16	3
142	SP-BC-26CC-142.3	LABEL RECOIL	-
143	SP-BC-26CC-143.3	LABEL COVER	1
144	SP-BC-26CC-144.3	GUARD	1
145	SP-BC-26CC-145.3	SCREW	2
146	SP-BC-26CC-146.3	CLIP	1

# EXPLODED DIAGRAM & PARTS LIST

## 36cc Brush Cutter Engine

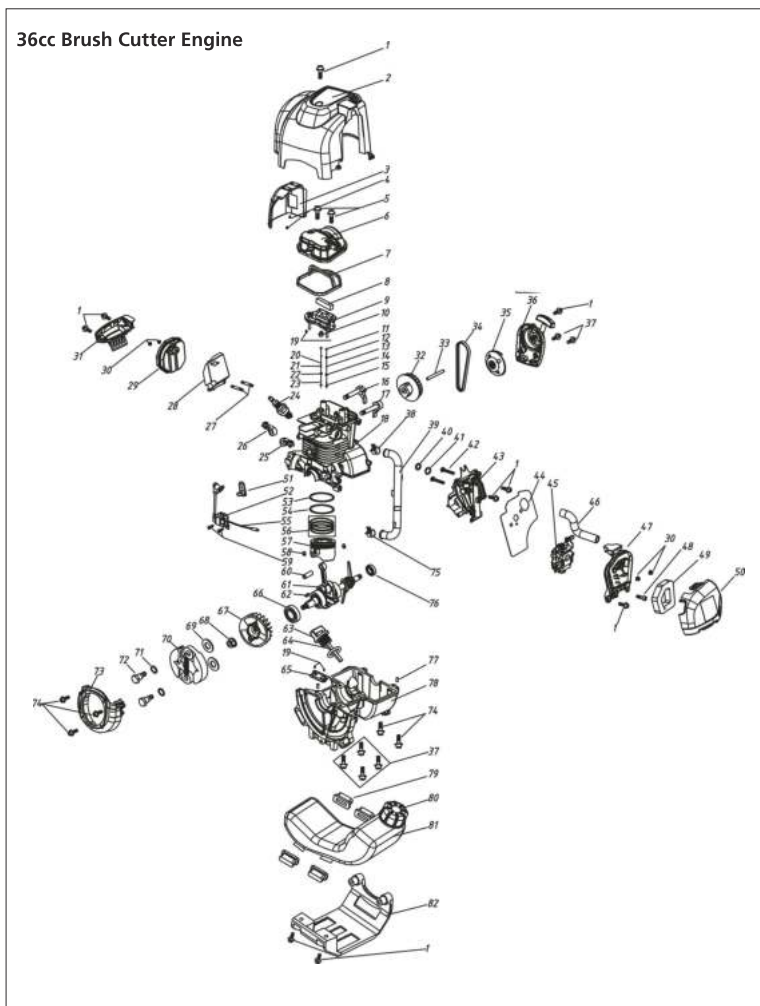

# EXPLODED DIAGRAM & PARTS LIST

## 36cc Brush Cutter Engine

NO	SKU	Description	QTY
1	SP-BC-36CC-001	Bolt M5 X 15	9
2	SP-BC-36CC-002	Engine Cover	1
3	3SP-BC-36CC-003	Muffler Heat Shield	1
4	SP-BC-36CC-004	Self Tapping Screw St3.9 X 10	2
5	SP-BC-36CC-005	Screw M5 X 12	2
6	SP-BC-36CC-006	Cylinder Cover	1
7	SP-BC-36CC-007	Cylinder Head Cover Gasket	1
8	SP-BC-36CC-008	Oil Gas Separation Block	1
9	SP-BC-36CC-009	Inside Cylinder Cover	1
10	SP-BC-36CC-010	Sealing Ring	1
11	SP-BC-36CC-011	Valve Spring Seat	2
12	SP-BC-36CC-012	Valve Spring	2
13	SP-BC-36CC-013	Intake Valve Guide	1
14	SP-BC-36CC-014	Intake Valve Seat	1
15	SP-BC-36CC-015	Intake Valve	1
16	SP-BC-36CC-016	Exhaust Plate	1
17	SP-BC-36CC-017	Intake Plate	1
18	SP-BC-36CC-018	Cylinder Block	1
19	SP-BC-36CC-078	Crankcase	1
20	SP-BC-36CC-019	Screw M4 X 8	4
21	SP-BC-36CC-020	Baffle Ring 7	1
22	SP-BC-36CC-021	Exhaust Valve Guide	1
23	SP-BC-36CC-022	Exhaust Valve Seat	1
24	SP-BC-36CC-023	Exhaust Valve	1
25	SP-BC-36CC-024	Spark Plug	1
26	SP-BC-36CC-025	Intake Valve Rocker Arm	1
27	SP-BC-36CC-026	Exhaust Valve Rocker Arm	1
28	SP-BC-36CC-027	Stud The M5 X 55	2
29	SP-BC-36CC-028	Muffler Baffle	1
30	SP-BC-36CC-029	Muffler	1
31	SP-BC-36CC-030	Nut M5	4
32	SP-BC-36CC-031	Baffle	1
33	SP-BC-36CC-032	Cam	1
34	SP-BC-36CC-033	Camshaft	1
35	SP-BC-36CC-034	Timing Belt	1
36	SP-BC-36CC-035	Starter Plate	1
37	SP-BC-36CC-036	Starter	1
38	SP-BC-36CC-037	Screw M5 X 32	6
39	SP-BC-36CC-038	Little Clamp	1
40	SP-BC-36CC-039	Balanced Trachea	1
41	SP-BC-36CC-040	Intake Pipe Gasket	1

NO	SKU	Description	QTY
42	SP-BC-36CC-041	Sealing Ring	1
43	SP-BC-36CC-042	Screw M5 X 25	2
44	SP-BC-36CC-043	Intake Pipe	1
45	SP-BC-36CC-044	Carburettor Gasket	1
46	SP-BC-36CC-045	Carburettor	1
47	SP-BC-36CC-046	Waste Gas Pipe	1
48	SP-BC-36CC-047	Air Filter Inner Housing	1
49	SP-BC-36CC-048	Combination Screw M5 X 25	1
50	SP-BC-36CC-049	Filter	1
51	SP-BC-36CC-050	Air Filter Housing	1
52	SP-BC-36CC-051	Hook	1
53	SP-BC-36CC-052	Ignition Coil	1
54	SP-BC-36CC-053	Upper Piston Ring	1
55	SP-BC-36CC-054	Lower Piston Ring	1
56	SP-BC-36CC-055	Oil Scraper Ring Assy	1
57	SP-BC-36CC-056	Off Line	1
58	SP-BC-36CC-057	Piston	1
59	SP-BC-36CC-058	Piston Pin Ring	2
60	SP-BC-36CC-059	Bolt M4 X 16	2
61	SP-BC-36CC-060	Piston Pin	1
62	SP-BC-36CC-061	Crankshaft Assy	1
63	SP-BC-36CC-062	Key 3 X 5 X 13	1
64	SP-BC-36CC-063	Oil Gage	1
65	SP-BC-36CC-064	Sealing Ring 14 X 19 X 2.7	1
66	SP-BC-36CC-065	Reed Valve Assy	1
67	SP-BC-36CC-066	Oil Seal 25 X 15 X 6	1
68	SP-BC-36CC-067	Flywheel	1
69	SP-BC-36CC-068	Nut M8	1
70	SP-BC-36CC-069	Washer 8	2
71	SP-BC-36CC-070	Clutch	1
72	SP-BC-36CC-071	Wave Washer	2
73	SP-BC-36CC-072	Bolt	2
74	SP-BC-36CC-073	Fun Cover	1
75	SP-BC-36CC-074	Bolt M5 X 22	1
76	SP-BC-36CC-075	Big Clamp	1
77	SP-BC-36CC-076	Oil Seal 25 X 10 X 5	1
78	SP-BC-36CC-077	Pin B4 X 10	2
79	SP-BC-36CC-079	Rubber Damping Block	4
80	SP-BC-36CC-080	Tank Cap	1
81	SP-BC-36CC-081	Tank	1
82	SP-BC-36CC-082	Tank Bracket	1

# EXPLODED DIAGRAM & PARTS LIST

## 52cc Brush Cutter Engine

NO	SKU	DESCRIPTION	QTY
1	SP-BC-52CC-001	CLUTCH SPRING	1
2	SP-BC-52CC-002	CLUTCH BOLT M8	2
3	SP-BC-52CC-003	WASHER M8	2
4	SP-BC-52CC-004	CLUTCH	1
5	SP-BC-52CC-005	BOLT SET M5 X 20	4
6	SP-BC-52CC-006	FLYWHEEL COVER	1
7	SP-BC-52CC-007	FLANGE NUTS M8	2
8	SP-BC-52CC-008	FLY WHEEL	1
9	SP-BC-52CC-009	BOLT SET M5 X 35	4
10	SP-BC-52CC-010	BOLT SET M5 X 20	2
11	SP-BC-52CC-011	COIL	1
12	SP-BC-52CC-012	SPARK PLUG	1
13	SP-BC-52CC-013	BOLT SET M5 X 25	4
14	SP-BC-52CC-014	BOLT SET M5 X 12	1
15	SP-BC-52CC-015	COVER	1
16	SP-BC-52CC-016	BODY	1
17	SP-BC-52CC-017	BOLT SET M5 X 20	2
18	SP-BC-52CC-018	PISTON PIN	1
19	SP-BC-52CC-019	CYLINDER GASKET	1
20	SP-BC-52CC-020	PISTON RING	2
21	SP-BC-52CC-021	PISTON	1
22	SP-BC-52CC-022	PISTON NEEDLE 10 X 13 X 16	1
23	SP-BC-52CC-023	PISTON SPRING	2
24	SP-BC-52CC-024	CYLINDER	1
25	SP-BC-52CC-025	MUFFLER GASKET	1
26	SP-BC-52CC-026	MUFFLER GASKET	1
27	SP-BC-52CC-027	BOLT SET M5 X 12	1

NO	SKU	DESCRIPTION	QTY
28	SP-BC-52CC-028	WASHER M6	2
29	SP-BC-52CC-029	BOLT M6 X 55	2
30	SP-BC-52CC-030	COVER	1
31	SP-BC-52CC-031	BOLT SET M5 X 12	1
32	SP-BC-52CC-032	BIG OIL SEAL	1
33	SP-BC-52CC-033	WOODRUFF KEY 3 X 12	1
34	SP-BC-52CC-034	CRANKSHAFT	1
35	SP-BC-52CC-035	BODY GASKET	1
36	SP-BC-52CC-036	BEARING 6202	2
37	SP-BC-52CC-037	SMALL OILSEAL 12 X 22 X 7	1
38	SP-BC-52CC-038	PAWL	1
39	SP-BC-52CC-039	PULL START ASSY	1
40	SP-BC-52CC-040	BOLT SET M5 X 20	4
41	SP-BC-52CC-041	CARBY MOUNT GASKET	1
42	SP-BC-52CC-042	CARBY MOUNT	1
43	SP-BC-52CC-043	BOLT SET M5 X 25	2
44	SP-BC-52CC-044	CARBURETTOR GASKET	1
45	SP-BC-52CC-045	CARBURETTOR	1
46	SP-BC-52CC-046	AIR FILTER ASSY	1
47	SP-BC-52CC-047	BOLT M5 X 55	2
48	SP-BC-52CC-048	WASHER M5	1
49	SP-BC-52CC-049	BOLT M5 X 16	1
50	SP-BC-52CC-050	FUEL PIPE SEAL	1
51	SP-BC-52CC-051	OIL FILTER	1
52	SP-BC-52CC-052	OIL PIPE	2
53	SP-BC-52CC-053	FUEL TANK	1
54	SP-BC-52CC-054	FUEL TANK GUARD	1

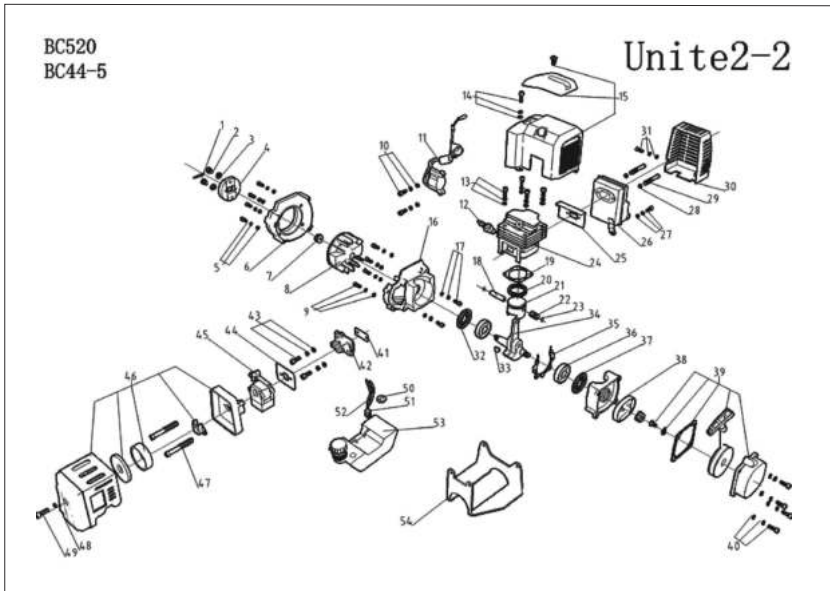

# EXPLODED DIAGRAM & PARTS LIST

## 52cc Brush Cutter Shaft

NO	SKU	DESCRIPTION	QTY
1	SP-BC-52CC-001.1	DRUM	1
2	SP-BC-52CC-002.1	SNAP RING $\Phi 35$	1
3	SP-BC-52CC-003.1	BEARING 6202RS	1
4	SP-BC-52CC-004.1	SNAP RING $\Phi 15$	1
5	SP-BC-52CC-005.1	CONNECTOR	1
6	SP-BC-52CC-006.1	SNAP RING $\Phi 30$	1
7	SP-BC-52CC-007.1	BOLT SET M6x16	4
8	SP-BC-52CC-008.1	JOINT	1
9	SP-BC-52CC-009.1	BOLT SET M5x20	3
10	SP-BC-52CC-010.1	BOLT SET M5x12	1
11	SP-BC-52CC-011.1	NUT M6x20	1
12	SP-BC-52CC-012.1	OIL-RETAINING BEARING	5
13	SP-BC-52CC-013.1	ALUMINIUM SHAFT $\Phi 26 \times 1530$	1
14	SP-BC-52CC-014.1	DRIVE SHAFT $\Phi 8$	1
15	SP-BC-52CC-015.1	SPRING WASHER M5	4
16	SP-BC-52CC-016.1	BOLT M5x25	4
17	SP-BC-52CC-017.1	CONNECTOR SET	1
18	SP-BC-52CC-018.1	BOLT SET M5x25	2
19	SP-BC-52CC-019.1	BOLT M5x16	1
20	SP-BC-52CC-020.1	NUT M5	1
21	SP-BC-52CC-021.1	BUSHING	1
22	SP-BC-52CC-022.1	RIGHT HANDLE	1
23	SP-BC-52CC-023.1	SNAP RING $\Phi 26$	1
24	SP-BC-52CC-024.1	SNAP RING $\Phi 10$	1
25	SP-BC-52CC-025.1	BEARING 6000RS	3

NO	SKU	DESCRIPTION	QTY
26	SP-BC-52CC-026.1	GEAR	1
27	SP-BC-52CC-027.1	GEARCASE	1
28	SP-BC-52CC-028.1	GEAR	1
29	SP-BC-52CC-029.1	OUTPUT SHAFT	1
30	SP-BC-52CC-030.1	BEARING 6002RS	1
31	SP-BC-52CC-031.1	SNAP RING $\Phi 32$	1
32	SP-BC-52CC-032.1	COVER	1
33	SP-BC-52CC-033.1	SPRING WASHER M5	3
34	SP-BC-52CC-034.1	NUT M5x10	3
35	SP-BC-52CC-035.1	DOWN COVER	1
36	SP-BC-52CC-036.1	UP COVER	1
37	SP-BC-52CC-037.1	COVER	1
38	SP-BC-52CC-038.1	NUT M10	1
39	SP-BC-52CC-039.1	LEFT HANDLE	1
40	SP-BC-52CC-040.1	NUT M6x16	2
41	SP-BC-52CC-041.1	GUARD CLAMP	1
42	SP-BC-52CC-042.1	GUARD	1
43	SP-BC-52CC-043.1	GUARD BLADE	1
44	SP-BC-52CC-044.1	NUT M3x8	3
45	SP-BC-52CC-045.1	BOLT SET M5x12	1
46	SP-BC-52CC-046.1	BOLT SET M5x20	1
47	SP-BC-52CC-047.1	BOLT SET M6x12	1
48	SP-BC-52CC-048.1	BUTTER HEAD	1
49	SP-BC-52CC-049.1	3T BLADE	1

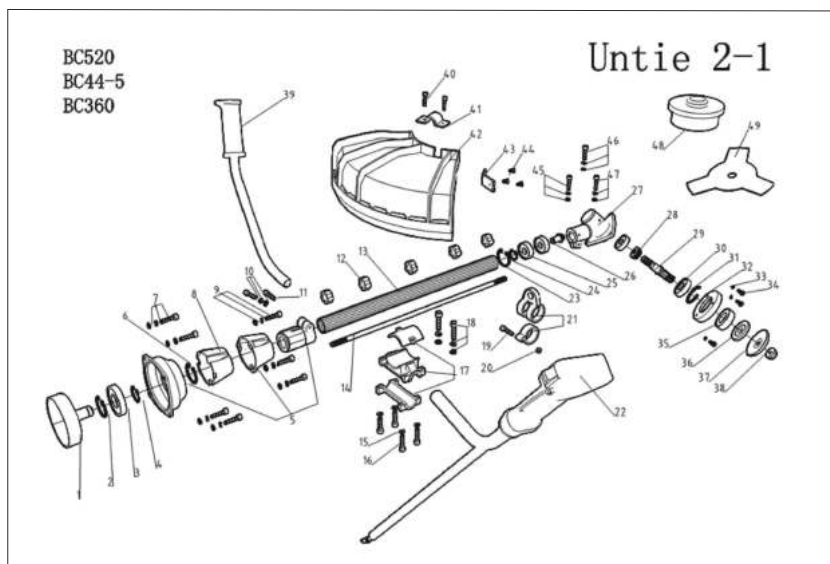

## YOU MAY ALSO LIKE



Chainsaws



Blowers



Lawn Mowers



Chainsaw Sharpeners

Enquiry or problems with our products?

**CALL US (02) 4257 4787**



**[www.bbta.com.au](http://www.bbta.com.au)**

COPYRIGHT © BIGGER BOYZ TOYZ AUSTRALIA PTY.LTD  
Unit 2/3 Delta Place Albion Park Rail NSW 2527  
BBT-BC-26CC-MNL1806